

**AREA CLASSIFICATION FOR
LANDFILL GAS EXTRACTION,
UTILISATION AND COMBUSTION**

INDUSTRY CODE OF PRACTICE

ESA ICoP 2, edition 1: Nov. 2005



This work was commissioned by ESA and funded by Biffa, EnerG, the Environmental Services Training and Education Trust (ESTET), SITA UK and Viridor Waste Management.

SIRA Certification was contracted to produce this document for ESA Members and we acknowledge their technical contribution and assistance in preparation of this document.

November 2005

Published by
ESA
154 Buckingham Palace Road
London
SW1W 9TR
Tel: 0207 824 8882

Available for download from ESA's web site:
http://www.esauk.org/publications/reports/DSEAR_guidance.asp

CONTENTS

CONTENTS	3
1 INTRODUCTION AND SCOPE	6
1.1 Executive summary	6
1.2 Principal codes of practice referenced	6
1.3 Scope	7
2 DEFINITIONS AND TERMS	8
3 PROPERTIES OF LANDFILL GAS	9
4 THE PRINCIPLES OF AREA CLASSIFICATION	10
4.1 Safety principles	10
4.2 Area classification terminology	11
4.2.1 Grades of release	11
4.2.2 Zone definitions	11
4.2.3 Relationship between grades of release, zones and installed equipment	12
4.2.4 Catastrophic failures	12
4.3 Limitations of existing CoPs	12
4.4 Information needed for area classification	12
4.5 Equations used in this ICoP	14
4.5.1 Mass flow rate equation	14
4.5.2 Volume flow rate equation	14
4.5.3 Zone radius equation for outdoor releases	15
4.5.4 Worked example 1 to find the zone radius from a leaking flange	16
4.5.5 Worked example 2 to find the zone radius from a gas well venting freely	16
4.5.6 When to use the calculation method	17
5 AREA CLASSIFICATION for LANDFILL GAS EXTRACTION	17
5.1 Overview of landfill gas extraction	17
5.2 Uncapped landfill sites	17
5.3 Zoning around flanges, screwed fittings, joints and valve glands	18
5.4 Sampling	18
5.5 Dipping points	19
5.6 Vertical gas well and wellhead	19
5.7 Pin wells	22
5.7.1 Pin wells in uncapped areas	22
5.7.2 Pin wells in capped areas	23
5.8 Gas Scavenger Pipes (horizontal gas wells)	23
5.9 Perimeter boreholes	24
5.10 Leachate extraction points	25
5.11 Leachate recirculation injection	26
5.12 Gas collection manifold	26
5.13 Pipework from manifold to booster	28
5.14 Knock-out pots	28
5.15 Passive vents	29
5.16 Drilling operations	29
6 area classification FOR landfill gas UTILISATION AND COMBUSTION	30
6.1 Overview of power generation from landfill gas	30
6.2 Manual sampling	31
6.3 Continuous gas monitoring	31
6.4 Gas booster – freely-ventilated	31
6.5 Gas booster – enclosed	32
6.6 Flame arrestor	33
6.7 Separator/knock-out vessel	33
6.8 Condensate cyclone/separator	35
6.9 In line gas filter systems	35
6.10 Gas receivers (pressurised systems, gas compressors)	36
6.11 Engine enclosures	36
6.12 Multi-engine facilities	37
6.13 Flares and associated pipework	37
6.14 Vents	38
APPENDIX 1 References	39

LIST OF FIGURES

Figure 1: zoning for an exposed vertical gas well at up to 13 mbarg.....	22
Figure 2: zoning for a pin well.....	23
Figure 3: zoning for a typical gas scavenger pipe.....	24
Figure 4: zoning for a leachate riser	26
Figure 5: zoning for a pipework manifold	27
Figure 6: zoning for a typical pumped knock-out pot.....	29
Figure 7: typical process flow in a gas generating compound.....	30
Figure 8: shaft leak diameter	32
Figure 9: zoning for separator/knock-out vessel with manual drain.....	34
Figure 10: zoning for float-operated valve type separator	35

LIST OF TABLES

Table 1: variation of molecular mass with % methane.....	15
Table 2: zone radii around wells due to failure of the Bentonite seal.....	21
Table 3: Booster pump at 150mbarg – level I leak	32
Table 4: Booster pump at 200mbarg – level I leak	32
Table 5: Booster pump at 250mbarg – level I leak	32
Table 6: Booster pump at 300mbarg – level I leak	32
Table 7: Booster pump at 350mbarg – level I leak	32
Table 8: zone radii from releases at 4 barg	36
Table 9: downward dispersion of potentially explosive atmospheres from outdoor venting	38

FOREWORD

James Barrett, Head of the Manufacturing Sector of the Health and Safety Executive

This code has been prepared by the Environmental Services Association in consultation with the Health and Safety Executive and has been endorsed by the Waste Industry Safety and Health (WISH) Forum which represents the interests of the industry.

This Code should not be regarded as an authoritative interpretation of the law, but if you follow the advice set out in it you will normally be doing enough to comply with health and safety law in respect of those specific issues on which the Code gives advice. Similarly, Health and Safety Inspectors seeking to secure compliance with the law may refer to this Guidance as illustrating good practice.

The HSE believes that the contents of this Code demonstrate good practice in the landfill industry and commends its use.

ACKNOWLEDGEMENTS

This Landfill Industry Code of Practice was prepared by the following members of the Steering Group representing the landfill industry and external consultants:

Andrew Cox	EnerG Natural Power Limited, EnerG House, Daniel Adamson Road, Salford, Manchester M50 1DT
David Holton	Sira Certification, Eccleston, Chester CH4 9JN
Peter Murdoch	Sira Certification, Eccleston, Chester CH4 9JN
Paul Rogers	for Biffa Waste Services Limited, Cressex Head Office, Coronation Road, Cressex Business Park, High Wycombe, HP12 3TZ
Neil Taylor	Viridor Waste Management, Great Western House, Station Approach, Taunton, TA1 1QW
Ian Walker	Technical Manager, Sita Power, Sita UK, Packington House, Packington Lane, Little Packington, Meriden, Coventry CV7 7HN

Contributions from the following persons and/or bodies are gratefully acknowledged:

-	ESA Executive Committee
-	ESA Landfill, Pre-Treatment and Logistics Committee
-	Health and Safety Executive
-	Summerlease Re-Generation Limited
Julie Brown	Regional EQHS Auditor/Advisor, Biffa Waste Services
Peter Brown	Safety Implementation Manager, Biffa Waste Services
Michelle Conway	Development Manager, Biffa Waste Services
Sergi Cuadrat	Biogas Technology Limited
Paul Ellis	Environmental Control Advisor, Biffa Waste Services
Andrew Goode	Novera Energy
Paul Gough	General Manager, Roxby Landfill Site, Biffa Waste Services
Tim Gunn	Engineer, Environmental Technology, Biffa Waste Services
Stuart Hayward-Higham	Sita UK Limited; Chair of ESA Working Group
Ian Hill	Clarke Energy
Marian Kelly	ESA Working Group
Rafal Lewicki	Biogas Technology Limited
Chris Males	Development Assistant, Biffa Waste Services
Paul McParland	Cleanaway
Tim Otley	Sita UK Limited; ESA Working Group
Chris Parry	Biffa waste Services Limited; ESA Working Group
Dick Turner	Viridor Waste Management; ESA Working Group
Graham Wilkins	Technical Manager, Environmental Technology, Biffa Waste Services
Geoff Winckles	Institution of Gas Engineers and Managers

In this document, footnotes are indicated with number ⁽¹⁾ and endnotes (references to documents used) with a letter ^(A).

1 INTRODUCTION AND SCOPE

1.1 Executive summary

This document (ESA ICoP 2) is one of a number called up by the primary document (ESA ICoP 1) that, together, advise on how to fulfil the requirements of the Dangerous Substances Explosive Atmospheres Regulations:2002 ('DSEAR')^A for the waste management industry. ICoP 2 is concerned only with landfill gas; this contains a high proportion of methane and when released into the atmosphere, it mixes with the air and forms a potentially explosive atmosphere. As a result, DSEAR requires that the process of area classification be carried out to identify where such potentially explosive atmospheres could form.

This Landfill Industry Code of Practice for area classification (referred to throughout this document as the Landfill 'ICoP') attempts to apply existing codes of practice (CoPs) to the specific situations found in landfill gas collection and power generation. Although the experience of the industry has been incorporated into this document, very little additional research relating to area classification is available, so this Landfill ICoP aims to apply established area classification methodology to the problem of landfill gas. This ICoP comprises a set of recommendations only and is not mandatory, but is intended to represent good practice. This ICoP is mainly concerned with a site that is up-and-running and not at its start-up phase nor its running-down phase. Site-specific factors should always be considered when applying this ICoP, e.g.

- ◆ landfill gas with methane concentrations above 60% v/v¹,
- ◆ significant generation of hydrogen or hydrogen sulphide²,
- ◆ parts of the site where a mixture within the flammable range might be present for extended periods within the collection system,
- ◆ overpressures above 80 mbarg and 350 mbarg in the collection and generation respectively.

Throughout the ICoP, there are situations covered that may require additional verification of the validity of the assumptions.

It is envisaged that this Edition will be reviewed and re-issued by the end of 2006. Comments from the industry are welcomed and should be sent to ESA (m-kelly@esauk.org) before 1 July 2006.

1.2 Principal codes of practice referenced

The European code of practice on area classification is EN 60079-10:2003^B, which is technically identical to IEC 60079-10:2002. Section 1 of EN 60079-10:2003 contains the following statement:

"For detailed recommendations regarding the extent of the hazardous areas in specific industries or applications, reference may be made to the codes relating to those industries or applications".

A number of industry CoPs are available that supplement the information in EN 60079-10:2003 and give more specific guidance for certain industries but no CoP exists for the waste management industry. This Landfill ICoP therefore aims to provide a standardised approach to the classification of hazardous areas in the landfill industry, based on the principles of EN 60079-10 but also using guidance from other published CoPs where appropriate. The intention is that as many as possible of the standard situations will be included in this Landfill ICoP to allow the area classification of landfill facilities to be performed in a consistent manner across the industry by suitably-qualified persons.

The main CoP referenced in addition to EN 60079-10 is the Institute of Gas Engineers IGE/SR/25 code^C, since this applies to natural gas, which is similar to landfill gas. However, IGE/SR/25 does not deal specifically with the low pressures encountered in the waste industry, so, although the mass release equations have been adapted from this code, zone extents have been obtained by calculation.

Article 7(1) of the ATEX 94/9/EC Directive^D (enacted in the UK by means of DSEAR Regulation 7) makes area classification a legal requirement throughout Europe and, on a particular site, it is the Site/Facility Manager who holds the final responsibility to ensure it is complied with. The primary purpose of area classification of hazardous areas is to allow the selection of suitable electrical and non-electrical apparatus as well as

¹ Higher methane concentrations will not affect the zone number, but will slightly increase the zone extents for releases into the surrounding air

² Hydrogen sulphide is flammable but it is also highly toxic. It is highly unlikely that sufficient hydrogen sulphide can be produced to give a flammable risk – the LEL is 4.3%, which equates to 43,000ppm, so its toxic nature is far more important than its flammable nature.

identifying areas where additional precautions are required as a result of the explosion risk. Within this Landfill ICoP, a 'hazardous area' is one in which a flammable gas/air mixture is, or could be, present.

1.3 Scope

This Landfill ICoP should be applied in the design of new works, the refurbishment of existing works and where no area classification currently exists. This document does **not** consider

- ◆ drilling operations, for which a safe system of work is currently being developed in association with the relevant bodies;
- ◆ maintenance operations, for which a safe system of work should be applied;
- ◆ catastrophic failures, within the meaning EN 60079-10:2003 (see section 4.2.4);
- ◆ safety issues associated with toxic, asphyxiant or other hazards associated with landfill gas;
- ◆ utilisation systems with a delivery pressure above 350 mbarg;
- ◆ landfill site activities concerned with flammable materials other than landfill gas. In some cases, standard guidance is available apart from that already referenced in this Landfill ICoP ^{E F G H I J K}. However, further work may be required for situations specific to the waste management industry. Such activities include:

- Leachate storage, treatment and disposal (ESA ICoP 3)
- Drilling (ESA ICoP 4)
- Operations (landfill) (ESA ICoP 5)
- Operations (treatment) (ESA ICoP 6) including liquid treatments/solidification, advanced conversion technologies, aerosol destruction facilities
- Solid waste non-destructive facilities (ESA ICoP 7), including civic amenity (CA) sites, transfer stations and materials recycling facility (MRF)

2 DEFINITIONS AND TERMS

Some of the definitions below are specific to landfill gas extraction.

Term	Explanation
apparatus group	the part of the certification code (IIA, IIB, IIC or II) that indicates the range of gases and vapours for which the equipment is suitable. Equipment marked IIC or II is suitable for all gases and vapours (provided the temperature class is appropriate). IIB equipment is suitable for IIA and IIB gases. IIA equipment is suitable only for IIA gases.
area classification	the process of zoning the site to delineate between hazardous areas and non-hazardous areas
basal seal	clay liner, plastic membrane or other impermeable material underneath the waste, primarily engineered to prevent leachate from seeping into the ground below the landfill.
category 1G equipment	equipment with a very high level of protection, suitable for installation in zone 0 ³ ; it may equally be used in zones 1 and 2. Most Category 1G electrical equipment is protected by intrinsic safety.
category 2G equipment	equipment with a high level of protection, suitable for installation in zone 1; it may equally be used in a zone 2.
category 3G equipment	equipment with a standard level of protection, suitable for installation in zone 2.
condensate	the liquid that forms as the landfill gas cools
grades of release	see section 4.2.1
hazardous area	an area where there is a reasonable probability of finding a potentially explosive atmosphere
leachate	water-based liquid that collects in a landfill site, containing numerous contaminants depending on the constituents in the landfill mass
lower explosive limit (LEL)	the minimum amount of flammable gas that, mixed with air, will produce a potentially explosive atmosphere; it is usually expressed as a percentage by volume
negligible extent	where the estimated volume of a potentially explosive atmosphere is small (less than 0.1 m ³ , equivalent to a sphere of radius 0.3 m) ⁴ , it is defined as having 'negligible extent' and no zoning applies.
non-hazardous area	an area where there is a negligible or extremely low probability of a potentially explosive atmosphere being present; such an atmosphere may be present under catastrophic ⁵ failure conditions
potentially explosive atmosphere (PEA)	a mixture of gas and air that is within the flammable range, i.e. between the LEL and UEL
temperature class	Equipment is designated with a temperature class, T1 to T6; T6 equipment is the coolest (below 85°C), whereas T1 equipment is the hottest (below 450°C). Gases and vapours are also assigned temperature classes T1 to T6 to allow suitable equipment to be chosen.
upper explosive limit (UEL)	the maximum amount of flammable gas that, mixed with air, will produce a potentially explosive atmosphere; it is usually expressed as a percentage by volume
zones (0, 1, 2)	see section 4.2.2

³ Note that equipment should ideally be installed in the non-hazardous area or, if in a hazardous area, in the zone of least risk

⁴ Strictly speaking, a 'hypothetical volume' (V_z) of less than 0.1 m³ rather than a zone volume is the criterion for being "of negligible extent". EN 60079-10:2003 calculation 4 (conclusion) states that a V_z < 0.1 m³ allows the ventilation to be assessed as degree 'high'. From the definition of degree 'high' in clause B.3.1, a zone of negligible extent results.

⁵ See section 4.2.4

3 PROPERTIES OF LANDFILL GAS

The only flammable material addressed in this ICoP is landfill gas, which is produced by the anaerobic decomposition of organic matter. It is a mixture predominantly of methane (CH₄) and carbon dioxide (CO₂). The following description is for area classification only and is not intended to be a COSHH assessment.

Landfill gas is produced by the microbial degradation of biodegradable organic material present within the landfill. The degradation process takes place in five stages. The transition from one stage to the next being dependent upon many characteristics and therefore the time for which each stage is present is difficult to pre-determine. It is however, possible to have different stages of the degradation process taking place at any one time within a landfill site.

The factors that affect the production of landfill gas are typically:

- Waste composition (in particular the amount of readily degradable organic material)
- Density of the emplaced waste
- Moisture content and its distribution through the waste mass
- Acidity/alkalinity (pH) and nutrient availability (to feed the microbes).
- Temperature
- Presence of toxic agents and chemical inhibitors.

Stage 1 of the process, which is aerobic in nature, involves the consumption of any oxygen present within the waste, primarily by aerobic microbial activity. This process results in the main in the evolution of carbon dioxide gas, water and heat. Providing there are no sources of air ingress to the waste to replenish those consumed at this stage, then the concentration of oxygen will reduce. Nitrogen will decay as the gases produced purge it out from the waste mass.

Stage 2 of the degradation process involves the conversion from aerobic to anaerobic conditions within the waste mass, the results of this process being the production of ethanoic acid (acetic acid), ethanoates (acetates), ethanol, ammonia, carbon dioxide, hydrogen, water and heat. The hydrogen and carbon dioxide produced during this process continues to purge the remaining nitrogen from the atmosphere within the body of the waste.

Stage 3 of the degradation process is that where the methanogenesis process commences with methane and carbon dioxide being produced.

Stage 4 is where a period of equilibrium is reached in the degradation process. The conditions present in the body of waste provide a steady state condition during which methane and carbon dioxide are evolved in a ratio of typically 3:2 (60:40%) by volume.

Stage 5 represents the final stage of the degradation process during which the gas composition within the body of waste gradually assumes that of atmospheric air.

The composition of the landfill gas varies from one landfill site to another and within a landfill site, from one cell to another. The make up of the gas composition will change with time, the changes of which can be attributed to¹

- Differences in waste composition, pre-treatment and storage;
- Changes in the rate and predominant form of microbial activity e.g. aerobic/anaerobic;
- The age of the emplaced waste;
- Gas management regime;
- The hydraulic characteristics of the site;
- The physiochemical properties of waste components;
- The differing properties of the components of landfill gas e.g. solubility;
- Landfill temperature.

Landfill gas has the following properties:

Property	Value	Comments
Constituents	Methane (CH ₄)– 60% v/v Carbon dioxide (CO ₂)– 40% v/v 35.3% CH ₄ by mass	Proportions may vary but these values will be used for calculation purposes (see table below). CO ₂ is not flammable.
Molecular mass (M)	27.2 kg/kmol (60% CH ₄)	Methane has a molecular mass of 16; carbon dioxide has a molecular mass of 44. Therefore, landfill gas containing 60% methane will have a molecular mass as follows: $M = [(60 \times 16) + (40 \times 44)]/100$
Explosive limits ^M	4.4 – 16.5% v/v ⁶	Assumed as for pure methane ⁷ in air
Relative density (air = 1)	0.94	Air has an average molecular mass of 29 kg/kmol
Minimum temperature of landfill gas (for calculation purposes)	10°C	From LFTGN 03 ^N
Apparatus group	IIA	As for methane
Auto-ignition temperature	537°C	As for methane
Temperature class	T1	As for methane

Since landfill gas has the least onerous apparatus group and temperature class, all hazardous area equipment is suitable for use with landfill gas provided it has been correctly selected against other criteria, notably the zone.

In preparing this ICoP, the presence of hydrogen as a gas produced in the microbial decomposition of waste has not been considered. In general, as hydrogen is associated with the early stages of the degradation process, it is unlikely that gas extraction for power generation or utilisation (combustion) within a landfill gas flare would be initiated. However, it may be the case where some form of odour control involving gas collection from waste in stages 1 to 3 of the decomposition process is required. Also, monitoring may take place, releasing hydrogen. If this is the case, then a specific risk assessment based on actual measurements and conditions present should be undertaken to identify any risk of a potential explosive atmosphere being present with, where required, suitable and sufficient mitigating measures put in place. Hydrogen is a IIC/T1 gas.

There are many other components associated with the decomposition of waste – refer to LFTGN 04^O which addresses the health and environmental aspects, but not primarily the flammable risk.

4 THE PRINCIPLES OF AREA CLASSIFICATION

4.1 Safety principles

This sub-section is reproduced unchanged from EN 60079-10:2003 section 3.1.

Installations in which flammable materials are handled or stored should be designed, operated and maintained so that any releases of flammable material, and consequently the extent of hazardous areas, are kept to a minimum, whether in normal operation or otherwise, with regard to frequency, duration and quantity.

It is important to examine those parts of process equipment and systems from which release of flammable material may arise and to consider modifying the design to minimise the likelihood and frequency of such releases and the quantity and rate of release of material.

These fundamental considerations should be examined at an early stage of the design development of any process plant and should also receive prime attention in carrying out the area classification study. In the case of maintenance activities other than those of normal operation, the extent of the

⁶ BS EN 61779-1:2000 quotes 4.4% – 17%

⁷ It is likely that the LEL for landfill gas is higher than that of pure methane, on account of the CO₂ content, but the LEL for pure methane has been used where applicable in calculations.

zone may be affected but it is expected that this would be dealt with by a permit-to-work system⁸. In a situation in which there may be an explosive gas atmosphere, the following steps should be taken:

- a) eliminate the likelihood of an explosive gas atmosphere occurring around the source of ignition, or
- b) eliminate the source of ignition.

Where this is not possible, protective measures, process equipment, systems and procedures should be selected and prepared so the likelihood of the coincidence of a) and b) is so small as to be acceptable. Such measures may be used singly, if they are recognised as being highly reliable, or in combination to achieve an equivalent level of safety. EN 1127-1:1998^p may be a useful reference.

4.2 Area classification terminology

4.2.1 Grades of release

Potential releases of flammable materials are assigned 'grades of release', which are defined as follows in EN 60079-10:2003 section 2.7:

Grade of release	Definition
Continuous:	a release which is continuous or is expected to occur frequently or for long periods <i>(typically >1000 hours/year)</i>
Primary:	a release which can be expected to occur periodically or occasionally during normal operation <i>(typically between 10 and 1000 hours/year)</i>
Secondary:	a release which is not expected to occur during normal operation and, if it does occur, is likely to do so only infrequently and for short periods <i>(typically less than 10 hours/year and for short periods only)</i>

The text in *italics* is not part of the definitions in EN 60079-10 but is additional guidance found in IP15^q section 1.6.4. There is no clear definition of 'short periods' as applied to secondary grade releases, but EN 60079-10 Calculation No. 7 implies that a persistence time of less than one hour is consistent with the definition of a secondary grade release.

4.2.2 Zone definitions

The zone number assigned is based solely on the probability of an explosive atmosphere being present in a given location. Three probabilities are recognised:

High probability

Zone 0 A place in which an explosive atmosphere consisting of a mixture with air of flammable substances in the form of gas, vapour or mist is present continuously or for long periods or frequently.

Medium probability

Zone 1 A place in which an explosive atmosphere consisting of a mixture with air or flammable substances in the form of gas, vapour or mist is likely to occur in normal operation occasionally.

Low probability

Zone 2 A place in which an explosive atmosphere consisting of a mixture with air of flammable substances in the form of gas, vapour or mist is not likely to occur in normal operation but, if it does occur, will persist for a short period only.



Areas where there is an even lower probability of an explosive atmosphere being present can be classified as non-hazardous but possible catastrophic events⁹ leading to the formation of an explosive atmosphere in such areas are subject to a risk assessment.

⁸ The permit-to-work will include a risk assessment and will also consider procedures for safe systems of work

⁹ See section 4.2.4

4.2.3 Relationship between grades of release, zones and installed equipment

In unrestricted open-air locations, the following generally apply:

Grade of release	Corresponding gas/vapour zone	Zone designation
Continuous grade release	zone 0	
Primary grade release	zone 1	
Secondary grade release	zone 2	

Equipment manufactured against the ATEX Product Directive is marked to indicate its 'Category'. The category is used to select the zone or zones in which it may be used.

ATEX Category	Permitted zones of use	Design requirements
1G	0, 1, 2	safe with two independent faults or safe even when rare malfunctions are considered
1D	20, 21, 22	
2G	1, 2	safe when foreseeable malfunctions are considered
2D	21, 22	
3G	2	safe in normal operation
3D	22	

A fuller treatment of DSEAR compliance is covered in ESA ICoP 1.

The grade of release and zone are not synonymous. Poor ventilation may result in a more stringent zone (typical of pits, trenches and indoor situations where ventilation is limited). High levels of ventilation (e.g. local extract ventilation) may be used to allow a less stringent zone classification to be defined.

4.2.4 Catastrophic failures

It is important to note that area classification only deals with reasonably foreseeable events and does not consider highly improbable ('catastrophic') events. EN 60079-10 section 1.1(d) defines 'catastrophic' failures as "beyond the concept of abnormality dealt with in the standard" and lists "the rupture of a process vessel or pipeline and events that are not predictable" as examples. Thus, a 'catastrophic' failure may cause an explosive atmosphere to be present in an area defined by area classification as 'non-hazardous' and such situations are subject to a risk assessment by the operator under other legislation. Catastrophic failures are outside the scope of this ICoP.

The *extent* of the zone is dependent on a number of factors, e.g. the properties of the flammable materials, process pressure, leak aperture, ventilation, safety factors applied etc..

The process of area classification, therefore, involves the identification of all flammable materials, the identification and grading of all releases of flammable material, the assessment of the level of ventilation and/or housekeeping and the determination of the resulting types and extents of the zones. The allocation of zones enables the correct equipment, practices and procedures to be applied to protect the health and safety of the workers concerned with the facility.

4.3 Limitations of existing CoPs

The typical pressures involved in the landfill gas industry are very low and, indeed, much of the extraction side is at an underpressure. Where an overpressure is assumed, it is very modest by comparison with the pressures encountered in the process industry in general. Of the CoPs with national coverage, only IGE/SR/25 considers low pressures (down to 0.1 barg = 100 mbarg) and, in the absence of specific guidance for landfill gas, this CoP will be used as the primary source of guidance for mass release rates and zone extents.

4.4 Information needed for area classification

Area classification should be carried out by those who have knowledge of the properties of landfill gas, the process and the equipment, in consultation, as appropriate, with safety, electrical, mechanical and other engineering personnel.

This ICoP gives guidance on the procedure for classifying areas in which there may be an explosive gas atmosphere and on the extent of zones 0, 1 and 2. The area classification should be carried out when the initial process and instrumentation line diagrams and initial layout plans are available and confirmed before plant start-up. Reviews should be carried out during the life of the plant.

An example of a method for recording the area classification is given below. Its use is not mandatory but it may be useful where more unusual situations occur.

Plant:				Drawing:					Flammable material: landfill gas			
		Release		Operating temp. & press.		Ventilation			Hazardous area			
No	Plant item	Location	Grade	°C	mbar	Type	Degree	Availability	Zone no.	Zone radius (m)		See note #
										Vert.	Horiz	
1	see note A	see note B	see note C	see note D		note E	note F	note G	see note H	see note I		see note J
2												

Notes on the use of this table

- A Plant item: this means an item, such as a pin well, manifold, etc. and should include the relevant part of the item, for example "interior", "exterior around hatch". A single plant item may have two or more lines.
- B Location: where the item is physically located, e.g. "gas compound", "various locations on gas field", etc.
- C Grade: this refers to the grade of release, i.e. continuous, primary or secondary
- D Operating temperature and pressure: the temperature is likely to be "ambient"¹⁰ and the pressure either a modest over- or under-pressure. In this ICoP, landfill gas is assumed to be between 150 mbarg underpressure and 80 mbarg overpressure on the extraction side and typically up to 350 mbar on the delivery side of the gas booster system. The temperature is taken as 10°C.
- E Ventilation type: this is natural, artificial or both.
- F Ventilation degree: this is high, medium or low. Outdoors, ventilation is 'medium' degree, whereas indoors it will be 'low' if there is very little ventilation, 'medium' with, say, 12 air changes/hour and only 'high' where the air flow is so strong as to effectively dilute any release almost immediately to below its LEL, giving rise to a dilution zone of negligible size.
- G Ventilation availability: this can be 'good', 'fair' or 'poor'. Outdoors, availability is 'good'; indoors, where forced ventilation is used, it will generally only be 'good' if there is a standby fan that starts automatically if the duty fan fails.
- H Zone number: this can be 0, 1 or 2, as detailed in this ICoP
- I Zone extent: the size of the zone, as detailed in this ICoP
- J See note #: it is important that this is filled in to give a reference to the part of this (or another) document from which the zoning has been derived; also include any non-standard features and/or reasons for deviations from the ICoP.

¹⁰ Landfill gas temperature can be well above ambient but the temperature makes little difference to the calculated zone extent.

4.5 Equations used in this ICoP

4.5.1 Mass flow rate equation

IGE/SR/25 section 5.2.3.2 gives an equation that may be used to calculate the flow rate through an orifice for natural gas. Although this is not the same as landfill gas, it does allow the actual molecular mass to be inputted into the equation and gives a sufficiently accurate value of mass flow rate from a leak for the purposes of area classification. For pressures below 850 mbarg:

$$g = 1500 C_d A (MP/T)^{0.5} \quad \text{Equation 1}$$

where g = mass flow rate of landfill gas in kg/s through a leak
 C_d = coefficient of discharge of orifice = 0.8 (0.97 for relief valves)
 A = cross-sectional area of the orifice in m^2 ($1 \text{ mm}^2 = 10^{-6} \text{ m}^2$)
 M = molecular mass = 27.2 kg/kmol for landfill gas containing 60% v/v methane
 P = gas pressure in bar gauge (barg)
 T = absolute temperature of gas upstream of orifice in K ($10^\circ\text{C} = 283 \text{ K}^R$ assumed)

For simplicity, the temperature of release of landfill gas and the ambient temperature of the gas once release have both been taken as 10°C .

The cross-sectional area assumed in this ICoP for a leak from a flange, screwed fitting, joint or valve gland is based on guidance in IGE/SR/25 section 5.2.1.1, i.e. 0.25 mm^2 . This applies to 'normal' conditions and is generally applicable because pressures are low and temperature changes are modest. IGE/SR/25 recommends 2.5 mm^2 for an 'adverse' environment, but this value has not been used. If required, the equations in section 4.5 can be used to calculate the zone extent from this larger leak aperture where 'adverse' environments exist.

IGE/SR/25 Table 1 gives a zone radius of 0.5 m for pressures up to 2 barg ('normal' conditions). Since this table does not differentiate between the zone radii at 2 barg and 0.1 barg, the zone radii have been calculated from first principles using the equations in section 4.5, leading to zone extents smaller than those quoted in IGE/SR/25 Table 1.

4.5.2 Volume flow rate equation

EN 60079-10, IGE/SR/25 and IP15 do not give any equations for calculating the zone extent from a release of gas in a freely-ventilated outdoor location. An equation used by Sira Safety Compliance, based on empirical modelling of release rates to zone extents can be used to directly convert a volume release rate to a zone extent.

First, it is necessary to convert the mass release rate calculated from equation 1 to a volume release rate. This can be done using the Ideal Gas Equation found in standard physics text books; landfill gas is at sufficiently low pressure to approximate to ideal behaviour.

$$pV = nRT$$

where p = absolute pressure of the gas in Pa = 101325 Pa at atmospheric pressure
 V = volume of the gas in m^3
 n = number of moles¹¹ = (mass in kg)/(molecular mass in kmol) = g/M
 R = gas constant = 8314.4 J/kmol/K
 T = absolute temperature in K

Note that standard atmospheric pressure (101325 Pa) will be assumed: variations in atmospheric pressure have a very small effect on the calculations.

$$\begin{aligned} \text{Thus: } V &= nRT/p = gRT/Mp \\ &= (g \times 8314.4 \times T)/(M \times 101325) \\ V &= 0.0821gT/M \end{aligned}$$

¹¹ A mole is the molecular mass of a substance expressed in g. Thus, for methane, 1 mole is 16g. The molecular mass is therefore expressed in g/mol, which is numerically the same with units of kg/kmol.

Converting to volume/s and mass/s gives

$$Q_{LG} = 0.0821gT/M$$

where Q = volume flow rate of landfill gas in m³/s
 g = mass flow rate in kg/s
 T = absolute temperature of gas in K
 M = molecular mass = 27.2 kg/kmol for landfill gas (60% methane)

The constant in this equation (0.0821) has units and is derived by combining the individual constants for known parameters.

Since this ICoP assumes that landfill gas has a maximum of 60% methane by volume, the volume release rate of methane only is:

$$Q_{CH4} = 0.0493gT/M \quad \text{Equation 2}$$

where Q_{CH4} = volume flow rate of methane in m³/s *assuming 60% methane v/v.*

Note that the molecular mass of *landfill gas* is used, because the calculation is for the volume release rate of landfill gas, which is then multiplied by 0.6 to convert to a *methane* release rate.

For percentages of landfill gas other than 60%, the value of Q_{LG} can be calculated using the values of molecular mass in the table below and then multiplying by the appropriate value to obtain Q_{CH4}.

Table 1: variation of molecular mass with % methane						
% methane	30	40	50	60	70	80
M (kg/kmol)	35.6	32.8	30.0	27.2	24.4	21.6

4.5.3 Zone radius equation for outdoor releases

The zone radius can be calculated directly from the following empirical equation:

$$x = (1840Q_{CH4}/kE_{\%})^{0.55} \quad \text{Equation 3}^s$$

where x = zone radius (assumed a sphere) in m
 1840 = constant of proportionality derived from the empirical formula
 – this constant is not dimensionless
 Q_{CH4} = volume flow rate of methane in m³/s calculated from equation 2
 k = safety factor applied to the LEL
 0.5 for secondary grade releases *or*
 0.25 for primary grade releases
 E_% = lower explosive limit in % v/v

This equation takes account of obstructions caused by proximity to the ground, walls or other objects. It is only applicable to freely-ventilated outdoor locations and assumes a wind-speed sufficient for turbulent diffusion. EN 60079-10 section 4.4.5(a) states that 2 m/s is a minimum for this mechanism, whereas the minimum wind-speed that can be relied upon virtually continuously is only 0.5 m/s. Thus, the wind speed is not always sufficient for equation 3 to be fully applicable, so some 'layering' will occur at low wind-speeds. However, in view of the low pressure assumed (350 mbarg) and with the safety factor (k) included, this equation gives an acceptably conservative result for area classification purposes.

The zone radius is measured from the point of release in all directions, and is thus independent of the density of the release.

4.5.4 Worked example 1 to find the zone radius from a leaking flange

This worked example uses equations 1 to 3 to find the zone radius from a leaking flange on pipework containing landfill gas at 350 mbarg and 10°C.

Step 1: use equation 1 to calculate the mass release rate, g

$$g = 1500 C_d A (MP/T)^{0.5}$$

where g = mass flow rate of landfill gas in kg/s through a leak
 C_d = constant = 0.8 for most releases
A = cross-sectional area of the orifice in $m^2 = 0.25 \text{ mm}^2$
M = molecular mass = 27.2 kg/kmol for landfill gas
P = gas pressure in bar gauge (barg) = 0.35 barg
T = absolute temperature of gas upstream of orifice in K = 283 K

$$\begin{aligned} \text{Thus } g &= 1500 \times 0.8 \times (0.25 \times 10^{-6}) \times (27.2 \times 0.35/283)^{0.5} \\ &= 5.51 \times 10^{-5} \text{ kg/s (rounding up)} \end{aligned}$$

Step 2: use equation 2 to convert g to a volume release rate, Q

$$Q_{CH_4} = 0.0493gT/M$$

where Q_{CH_4} = volume flow rate of methane in m^3/s
g = mass flow rate in kg/s = $1.95 \times 10^{-5} \text{ kg/s}$ as calculated in step 1
T = absolute temperature of gas in K = 283 K
M = molecular mass for landfill gas = 27.2 kg/kmol

$$\text{Thus } Q_{CH_4} = 0.0493 \times 5.51 \times 10^{-5} \times 283/27.2 = 2.83 \times 10^{-5} \text{ m}^3/s$$

Step 3: use equation 3 to find the zone radius, x

$$x = (1840Q_{CH_4}/kE_{\%})^{0.55}$$

where x = zone radius in m
 Q_{CH_4} = volume flow rate of methane calculated in step 2 = $2.83 \times 10^{-5} \text{ m}^3/s$
k = safety factor applied to the LEL = 0.5 (for a secondary grade release)
 $E_{\%}$ = lower explosive limit in % v/v = 4.4

$$\text{Thus } x = (1840 \times 2.83 \times 10^{-5}/[0.5 \times 4.4])^{0.55} = 0.127 \text{ m, which will be rounded up to } \mathbf{0.2 \text{ m}}$$

4.5.5 Worked example 2 to find the zone radius from a gas well venting freely

This worked example assumes that the gas well is not under pressure but is in a steady-state venting situation whereby the entire production, taken as 30 m^3 /hour, is venting to atmosphere. This gives the zone radius around a Bentonite seal that has completely failed.

Equations 1 and 2 are not required since the volume release rate (Q_{CH_4}) is already known. Using equation 3:

$$x = (1840Q_{CH_4}/kE_{\%})^{0.55}$$

where x = zone radius in m
 Q_{CH_4} = volume flow rate of methane, which is 60% of 30 m^3/h
= $18 \text{ m}^3/h = 18/3600 = 0.005 \text{ m}^3/s$
k = safety factor applied to the LEL = 0.5 (for a secondary grade release)
 $E_{\%}$ = lower explosive limit in % v/v = 4.4

$$\text{Thus } x = (1840 \times 0.005/[0.5 \times 4.4])^{0.55} = 2.197 \text{ m, which will be rounded up to } \mathbf{2.2 \text{ m}}$$

4.5.6 When to use the calculation method

Zone extents for general situations involving leaks of landfill gas in outdoor locations can most easily be found by combining the equations above in a spreadsheet¹². Examples where the calculation method is appropriate are:

- ◆ sample points
- ◆ dipping points
- ◆ leaks from Bentonite seals

where the parameters are other than those given in the examples in this ICoP.

Do not use the calculation method for joints and valve glands, since section 5.3 deals with these.

In line with the precedent in IGE/SR/25, the zone extents calculated have been rounded up to the nearest 0.1 m where the value is less than 10 m. However, this does not imply that the accuracy of the method is such that results to ± 0.1 m can be obtained.

5 AREA CLASSIFICATION FOR LANDFILL GAS EXTRACTION

5.1 Overview of landfill gas extraction

This part of the Landfill ICoP deals with all aspects of the extraction of landfill gas, up to the booster. Drilling is to be covered in ICoP 4. Once wells have been drilled and connected to the main pipework system, landfill gas is extracted at a small underpressure (up to 150 mbarg), although there are a number of situations when this underpressure cannot be assumed, such as when a well is isolated from the collection pipework for maintenance reasons or when a high oxygen content is detected causing the well to be isolated and no longer subject to extraction.

5.2 Uncapped landfill sites

In sites or parts of sites that are uncapped, landfill gas generated within the waste will find its way to the surface and escape to atmosphere. The release of landfill gas is not uniform over the whole site, since fissures in the ground, underground obstructions, etc. will force the gas to take the route of least resistance to the surface, resulting in an uneven release distribution over the surface of the site.

This natural gassing process is a continuous grade release and could result in a flammable gas/air mixture on reaching the surface, but it is clearly impractical to assign a zone 0 over the entire uncapped mass. Where the landfill gas is escaping into a well-ventilated open location, as is the case over the vast majority of the site, then there is no risk of explosion and an ignition is highly unlikely to have a serious consequence. Higher release rates may be encountered, for example, close to:

- ◆ exposed drainage blankets
- ◆ exposed protection layers
- ◆ zones around leachate extraction structures
- ◆ areas of generally poor compaction

Therefore, although the phenomenon will be recognised, the zone will be assumed to be of negligible extent¹³ and will not therefore appear on area classification drawings¹⁴. Routine FID¹⁵ testing indicates significant concentrations only within a few centimetres of the ground; these are rarely within the flammable range.

The same approach will be used for the disposal of other flammables apart from landfill gas, such as solvents, aerosols, etc. Where these are included in the bulk compacted waste, they can also lead to gas or vapour emissions at the surface, but these will also be considered to give rise to a zone of negligible extent. The environmental issues are outside the scope of this document, which deals exclusively with the area classification implications.

¹² Electronic copies of the spreadsheets may be obtained by contacting ESA.

¹³ It is possible that a significant release rate could occur in some places (hence a zone of significant extent), but these locations are difficult to predict; experience over many years has shown that such higher-rate releases have not caused injury due to accidental ignition, so such an event can be assessed as presenting an acceptably low risk.

¹⁴ Care should be taken, however, to ensure that such gas cannot collect in enclosures on the surface, particularly those with a source of ignition, such as mobile generators (used for electrofusion (EF) welding), lighting, permanent structures.

¹⁵ FID = Flame Ionisation Detector

5.3 Zoning around flanges, screwed fittings, joints and valve glands

Guidance in IGE/SR/25 section 5.2.1.3 indicates that, for pressures up to 2 barg, a 0.5 m zone 2 is applicable around all joints and valves located in a freely-ventilated outdoor location and not subject to adverse conditions such as thermal shock, excessive vibration, etc.. This is to take account of unintentional leaks.

However, the actual maximum pressure of landfill gas is 80 mbarg in the collection side and up to 350 mbarg in the power generation side. Smaller zone radii of 0.1 m for all pressures up to 80 mbarg and 0.2 m up to 350 mbarg can be calculated using the equations in section 4.5 assuming a leak aperture of 0.25 mm² (the typical leak size from IGE/SR/25 section 5.2.1.1).

These zone radii may be applied where pipework is correctly-installed and regularly inspected. Where adverse conditions may apply (e.g. vibration, corrosion) and pipework is *not* regularly inspected, then the zone 2 radius of 1 m from IGE/SR/25 Table 1 should be used.

An inspection interval of not more than 6 months is recommended based on guidance in IGE/SR/25 Appendix 4, Tables 13 and 15.

Note: due to the potentially corrosive nature of landfill gas, metal pipes are more vulnerable to chemical attack from inside than plastic pipes.

Orifice plates (manufactured, for example, by Perflow) can be treated as a pair of flanges for the purpose of area classification.

Electro-fusion (EF) couplings and butt-fusion welded joints are highly reliable and are not considered as a source of release. The installation of pipework using this technique may involve working on 'live' pipes that are blocked using a 'pig'¹⁶ or by squeezing¹⁷ – this and other construction/maintenance activities are outside the scope of this ICoP.

There are some instances where uncertified electrical equipment is already installed within the zone from a flange, e.g. a flow meter or slam-shut valve. The use of uncertified equipment in zoned areas is dealt with more fully in ICoP 1¹⁸. However, to facilitate the risk assessment of whether uncertified equipment may remain in a zone 2 area, the information below may be useful.

Compared to the IGE/SR/25 code, guidance in IP15 section 5.4.5.1 allows a more relaxed approach to joints and valves in certain circumstances. The relevant extract is quoted below:

"For both individual flanges and valves, the likelihood of a release from an individual item is very unlikely and may not warrant classification as hazardous. If a risk-based approach is followed, such items may not require a specific hazardous area and only when there are a number of possible leak sources together should this area be classified. As a guide, where there are greater than 10 leak sources (from valves and flanges) within close proximity (i.e. where the zone 2 areas overlap), the area should be classified as a zone 2 area."

In the landfill industry, pressures are low and, on the collection side, the gas is usually at an underpressure. Even where the gas is at an overpressure, there are no operations leading to thermal shock or pressure hammer and the pipes are generally well-protected. There is usually low occupancy. Non-classification of joints and valves aligns with the general principle adopted in section 5.2, whereby releases from uncapped areas (which could exceed the release rate from a flange or valve in certain cases) are also not classified. These factors may assist in deciding whether an uncertified item of electrical equipment needs replacing or not.

5.4 Sampling

5.4.1 In-waste gas extraction wells

Sampling is normally performed by opening the sample point (a 3 mm diameter hole) and attaching a flexible tube that allows a small volume of gas to be drawn through a hand-held gas analyser. The flammable gas is then vented to atmosphere. This will produce a zone 1, but of negligible extent.

¹⁶ A 'pig' is an inflatable bladder that is inserted into the gas main and inflated forming a gas-tight seal

¹⁷ Refer to the relevant safe operating procedure

¹⁸ Note, however, that *new* equipment must be ATEX-marked.

Sampling is a normal operation and opening the sample point would normally be classified as a primary grade release, but the underpressure reduces this to a secondary grade release, since sampling is not normally undertaken when an overpressure exists. The sample point may be left open, in which case landfill gas at up to 80 mbarg overpressure can escape through a hole of diameter 3 mm. Calculations based on the equations in section 4.5 give a zone 2 radius of 0.6 m for dilution to 0.5 LEL.

Intrinsically safe gas analysers are used on some but not all sites. Consideration should be given to the risk of using an uncertified gas analyser. Although outside the scope of this document, it is noted that the major risk from an ignition (itself a low risk) is a situation when the gas being sampled is within its explosive range, potentially allowing a flame to burn back into the pipe.

5.4.2 Perimeter monitoring boreholes

Perimeter monitoring boreholes are a special case: see section 5.9.

5.5 Dipping points

These are located on most gas wells and knock-out pots. Typically, a 1" plug is removed and a dipping probe lowered in. The operation takes a few minutes.

As with sampling, dipping is a normal operation and would normally be classified as a primary grade release, but the underpressure reduces this to a secondary grade release, since sampling is not normally undertaken when an overpressure exists. Landfill gas at up to 80 mbarg overpressure can escape through a hole of outside diameter 25 mm/1" (internal diameter 17 mm). Calculations based on the equations in section 4.5 give a zone 2 radius of 3.6 m for dilution to 0.5 LEL for this orifice size. A larger 50 mm/2" plug (internal diameter 34 mm) gives a 5.8 m zone 2.

This zone radius exceeds that calculated for leaks around the Bentonite seal (2.2 m - see section 5.6.2) and will be unacceptably large for certain locations. If the 3.6 m zone is impractical (e.g. there is fixed uncertified electrical equipment encompassed by the potentially explosive atmosphere), there are a number of possible options, for example:

Option 1: wait until the well is at an underpressure before performing the dipping;

Option 2: isolate the nearby fixed electrical equipment;

Option 3: perform a risk assessment (by a qualified person) to determine whether it is acceptable to allow the nearby fixed electrical equipment to remain energised.

Where dipping does extend the 2.2 m zone 2, it can be justified by being performed under a safe operating procedure that ensures potential ignition sources (e.g. vehicles) are excluded from the larger zone while dipping is in progress.

5.6 Vertical gas well and wellhead

5.6.1 Description of operation

The gas well is the primary point of landfill gas extraction from the waste. It consists of two sections:

- 1 a vertical perforated well liner
- 2 the wellhead

as shown in Figure 1 below.

The lower section of the well liner consists of a perforated polyethylene (or similar) pipe surrounded by gravel. The upper section is constructed from solid pipe and is sealed into the landfill cap with an inorganic clay-type material (e.g. 'Bentonite' or similar).

The wellhead consists of an interface fabrication and regulating valve. The valve may be a butterfly type fixed between flanges or a ball or gate type with threaded connections. Flexible joints are usually fitted where the wellhead enters the liner and between the wellhead and the gas collection pipe.

Where 'dipping' is required, the wellhead is terminated in a blank flange that is fitted with a screwed 1" (25 mm) BSP plug – this can be removed for dipping the gas well – see section 5.5.

In normal operation, the gas well is operated under a suction not exceeding 30 mbar. Air ingress cannot be reliably prevented and the presence of air in the landfill gas must be considered as part of normal operation, even though inadvisable. Air ingress is more likely in older landfill sites or on uncapped areas of active sites. Air ingress may be via the waste, the Bentonite seal, the mechanical joints or the sample taps (which may be damaged or inadvertently left open).

An overpressure is possible under foreseeable abnormal conditions, which may occur relatively frequently. This can be caused by an operator noticing a high oxygen content and closing the valve connecting the gas well to the collection pipework. An overpressure slowly builds up as the landfill gas is generated within the waste. A typical overpressure will not exceed 10 mbarg, with a maximum value of 80 mbarg recorded (excluding 'catastrophic' conditions). 80 mbarg has been used in calculations.

Since an overpressure is a relatively common malfunction, the area classification of the areas surrounding the well will assume that an overpressure exists for more than 10 hours a year.

5.6.2 Zoning

The following releases are identified:

Continuous grade releases:

- none

Primary grade releases:

- air ingress into the landfill gas¹⁹ via the waste mass or otherwise resulting in a mixture within the flammable range

Secondary grade releases (leak outwards only when an overpressure exists):

- Bentonite seal – leaks due to drying out and poor compaction
- sample taps – opening for sampling**
- flanged cover – leaking gasket*
- valve flange – leaking gasket*
- valve stem – leaking seal*
- joints on flexible hose (clips)*
- threaded pipe connections used on temporary gas collection systems*

** For sampling, see section 5.4.

* For leaking gaskets, valves and other connections, see section 5.3.

A well sunk in new waste is likely to contain a potentially explosive atmosphere. Once in production, the inside of the gas well is designated a hazardous area because ingress of air into the gas well is not uncommon and this could result in a potentially explosive atmosphere. Ingress results from a poor Bentonite seal or air being drawn in via the landfill. In addition, older gas wells may have significantly higher oxygen levels than fully productive wells. For this reason, the interior is designated a zone 1. A zone 2 is not appropriate since an explosive atmosphere could occur for more than 10 h/yr.

The gas well is usually under suction, so emissions of landfill gas will not normally occur even if there is a leak path. However, if the landfill gas is too rich in oxygen, the well may be isolated, in which case the pressure of landfill gas builds up inside and can leak out.

Of the secondary grade releases, leaks from the Bentonite seal or sample points give the largest mass release rates. However, the probabilities of these two events are different.

Leaks from Bentonite seal: such a release requires two abnormal conditions: the well being at overpressure and failure of the seal. Area classification does not normally consider two independent abnormal events, but a well at overpressure is unlikely though possible in normal operation. Therefore, leaks from the seal will be considered.

¹⁹ Normally, a primary grade release implies the fuel gas leaking into the air. However, the landfill gas is at a lower pressure than the air, so leaking of air into the landfill gas is, technically, a "release". It is primary grade because, although unwanted, it occurs relatively frequently.

Quantifying the leak aperture is difficult. A foreseeable failure mode would be the opening of a fissure, the size of which cannot be realistically estimated. The worst case would entail the entire well production to be lost via the seal.

A steady-state situation will be assumed, whereby the entire well production leaks out (estimated at a maximum of 30 m³/h). This volume flow rate equates to a mass flow rate of 0.0094 kg/s. A zone radius calculation based on equations in section 4.5 gives a zone 2 of 2.2 m in all directions from the point of release. This zone 2 encompasses smaller zones from sampling and leaks. [A maximum leak rate of 25 m³/h gives a zone radius of 2 m.].

Some gas wells have different maximum yield rates. Provided the worst-case yield can be reliably predicted based on experience and/or measurement, then the zone 2 around the gas well has the radius shown in Table 2 below. Note that the lower values generally apply to pin wells rather than gas wells.

Table 2: zone radii around wells due to failure of the Bentonite seal	
Release rate of well (m³/h)	Radius of zone 2 (x metres) (rounded up to 0.1m)
1	0.4
2	0.5
3	0.7
4	0.8
5	0.9
10	1.3
15	1.6
20	1.8
25	2.0
30	2.2
40	2.6
50	3.0

Note that dipping may increase the zone extent beyond that from the Bentonite seal where smaller values from the above table are taken.

Where the Bentonite seal is assessed as *not* subject to complete failure (e.g. increased depth, stable waste), a smaller zone may be assigned, equal to that of a flange. However, other releases (e.g. sampling, dipping) should still be considered.

Not all gas wells use a Bentonite seal. In some cases, a well is drilled through the plastic membrane (typically medium density polyethylene, MDPE), and the hole 'repaired' by being stitched to a collar on the well itself, providing a gas-tight seal.

Yet another method is using a geosynthetic clay liner (GCL), comprising a hessian-based mat that can seal holes caused by movement of the gas well.

These are relatively new technologies, so it is not possible to determine whether failure of these types of seal should be treated as a secondary grade release (leading to a zone 2, as for Bentonite) or as 'catastrophic' (i.e. highly improbable), leading to a non-hazardous area around the seal.

Figure 1: zoning for an exposed vertical gas well at up to 13 mbarg

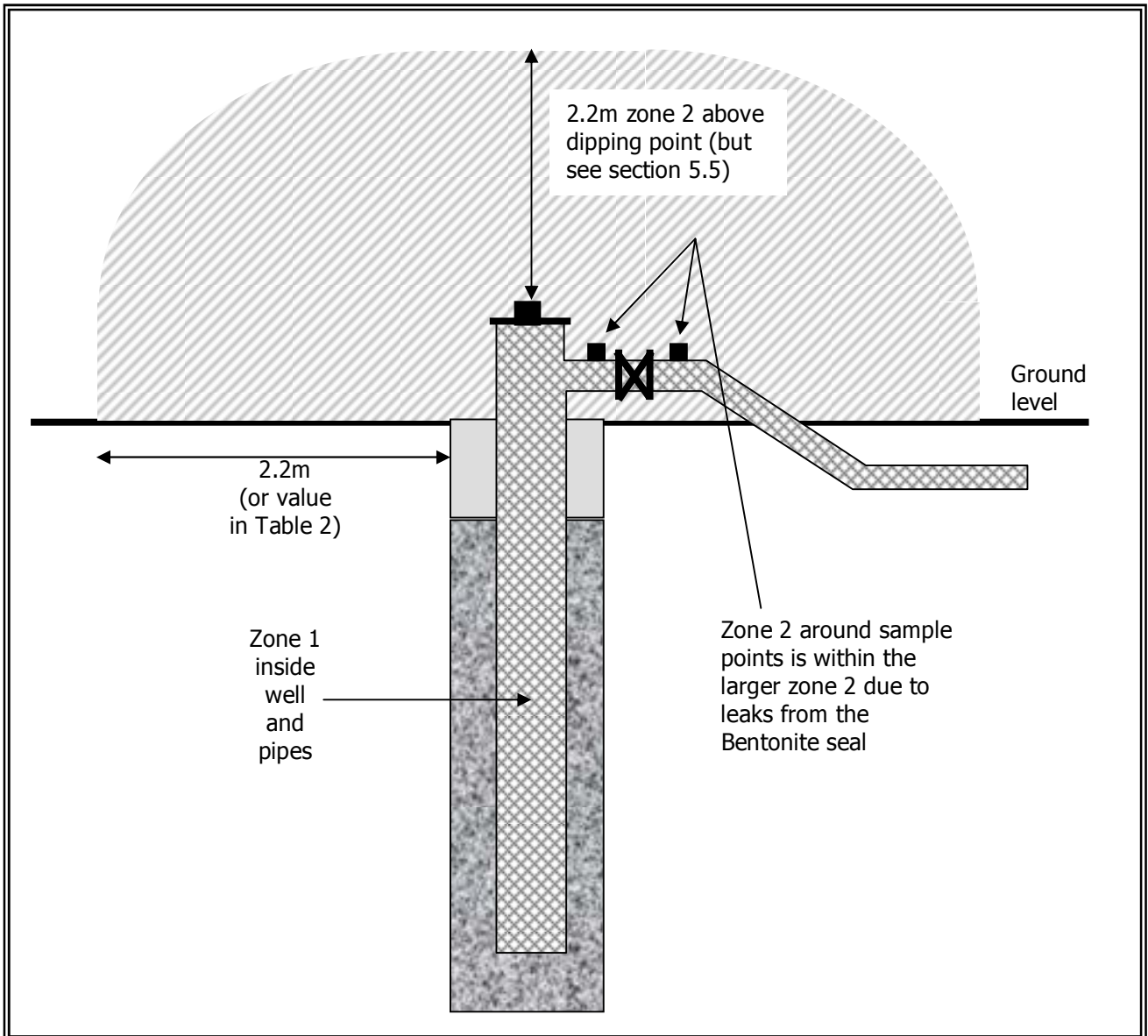

5.7 Pin wells

5.7.1 Pin wells in uncapped areas

Refer to Figure 2. A pin well is constructed by piling a metal spike (typically 6 m in length) into the waste, then withdrawn and a section of pipe inserted. Bentonite is sometimes used to seal around the hole, or they may be punched through the waste without further sealing. The pipe is slotted or perforated for the bottom 4-5 m and on the surface is connected to a valve. Like the gas well, it should be classified as zone 1 internally. They are generally temporary or sacrificial and may eventually be covered over as the filling depth increases; they are as little as 8 m from each other.

There are no external continuous or primary grade releases. The two secondary grade releases associated with pin wells are:

- ◆ valve seal
- ◆ leaks through the Bentonite seal

A small zone 2 is required around the valve seal – see section 5.3. The yield from a pin well is likely to be much less than from a gas well: a value of 5 m³/h is taken as a maximum. If this leaks out around the side of the pipe, the zone radii from Table 2 above can be applied, depending on the release rate of the pin well. Refer to section 3 for a discussion of hydrogen generation.

Figure 2: zoning for a pin well

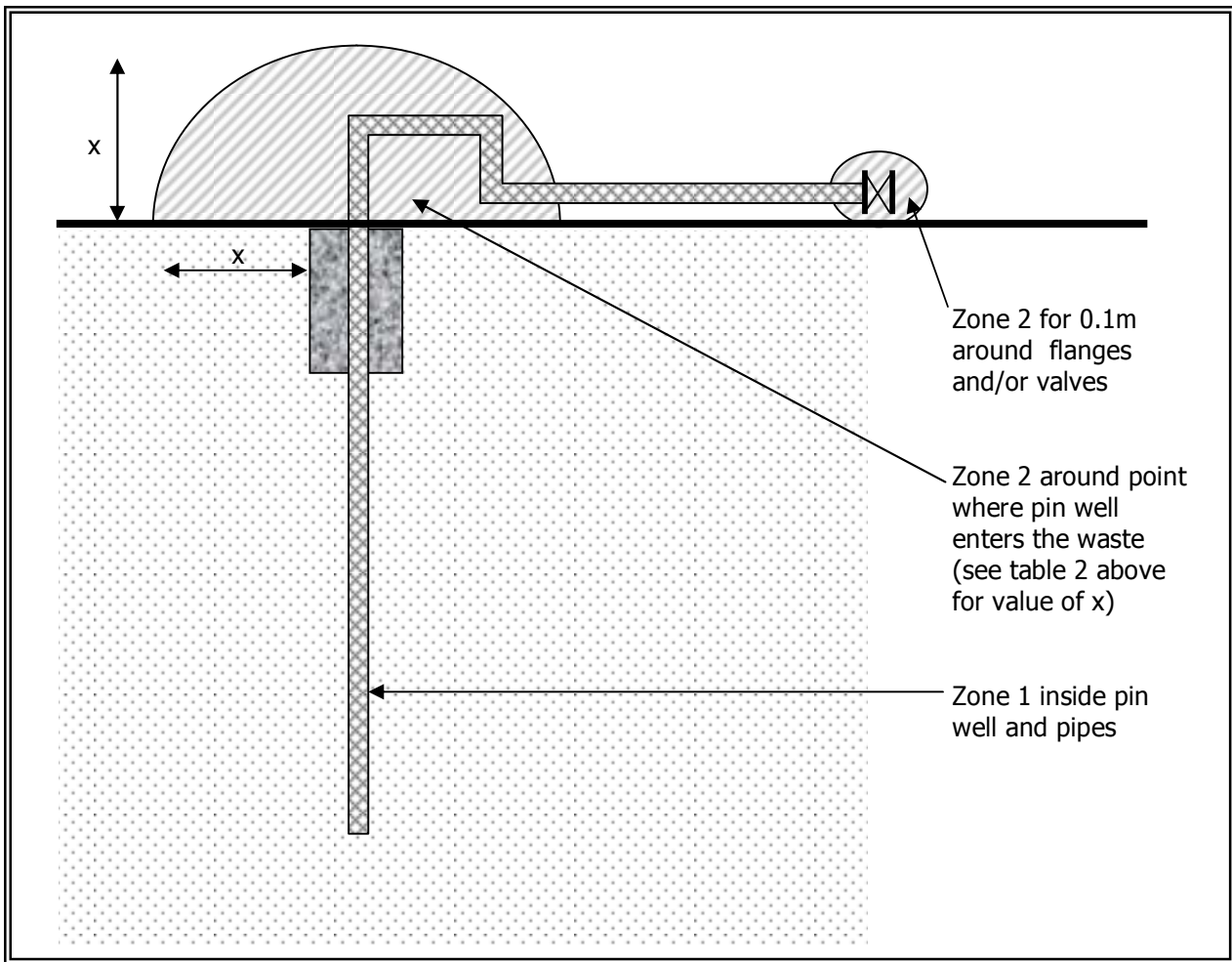

5.7.2 Pin wells in capped areas

Pin wells in capped areas are treated as gas wells (see section 5.6), i.e. a zone 2 for 2.2 m horizontally and vertically around the seal.

Since pin well installation is usually undertaken by outside contractors, this activity is currently outside the scope of this ICoP but is being dealt with in conjunction with the relevant bodies.

5.8 Gas Scavenger Pipes (horizontal gas wells)

The area classification of gas scavenger pipes is as for gas wells.

5.8.1 Description

Gas scavenger pipes are generally used as 'sacrificial' or temporary landfill gas collection systems and are the horizontal equivalent of a pin well. They are normally installed in temporary/uncapped active areas of the landfill, or as secondary/back-up landfill gas collection systems.

Scavenger pipes generally consist of fusion-welded pipes laid horizontally and perforated by drilling holes. Scavenger pipes are spaced according to the site-specific conditions – this may be typically from 5 to 20 metres. A length of solid pipe is used at the point where it leaves the waste mass to prevent air being drawn into the pipe. A seal is then formed between the waste mass and the pipework using either Bentonite (or equivalent) or an HDPE (or similar) sleeve-type coupling (known in the industry as a 'top hat').

Scavenger pipes normally terminate in a valved connection in a collection manifold chamber (see section 5.12).

In normal operation, due to the relatively high risk of air ingress through the waste, suction on scavenger pipes is likely to be less than 10 mbarg, although site-specific applications may dictate the use of higher levels of suction. In a fault situation, where gas extraction is lost, pressure within the scavenger pipe may rise typically to 80 mbar above atmospheric. In this situation leakage may occur at the rubber coupling or where the pipe exits the ground. There is also likely to be leakage through the uncapped waste above.

Gas scavenger pipes are normally very low maintenance. Operations may consist of taking gas samples, although this will more often be carried out at the gas collection manifold. Maintenance operations may include the connection and disconnection of scavenger pipes or repairs to any pipework damage.

Note that some scavenger pipes (or wells) are installed then covered with more waste, in which case the situation outside the pipe is similar to an uncapped landfill area – see section 5.2.

5.8.2 Zoning

Internally, the scavenger pipework is zone 1, for the same reason as the gas well. A zone 2 occurs where the scavenger pipe comes through the lining for connection to the main gas collection pipework. The radius of the zone 2 is the same as for the Bentonite seal of a gas well, i.e. 2.2 m (see section 5.6).

Figure 3: zoning for a typical gas scavenger pipe

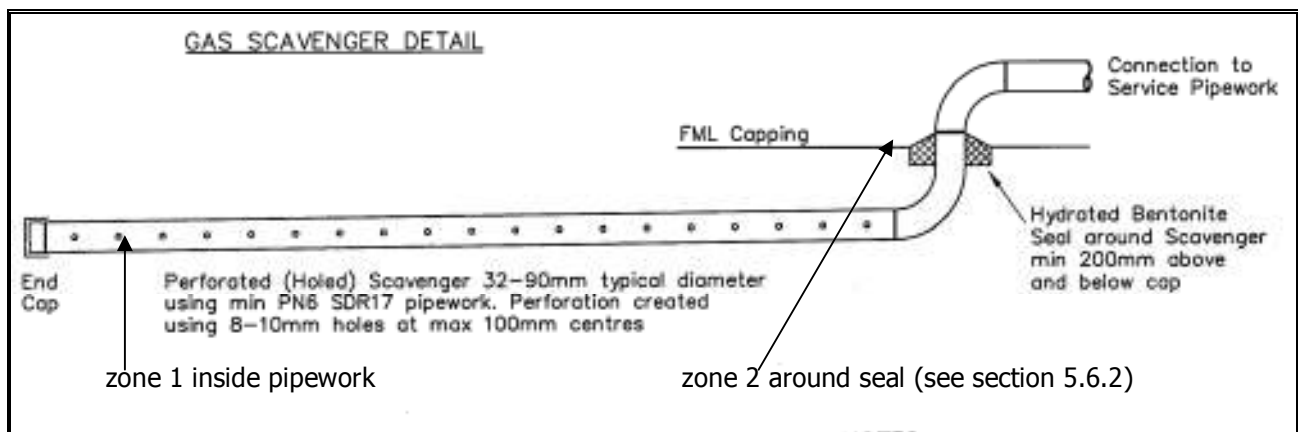

5.9 Perimeter boreholes

These are outside the waste boundary and are used to measure potential landfill gas migration. They are not usually connected to the extraction system but are capped. There are other potential sources of methane apart from that derived from waste, e.g. mines gas, peat gas or marsh gas. On some sites, there may be waste adjoining the controlled area that has been previously tipped.

The landfill gas may be above the LEL but only a small volume is contained in the borehole itself. On older or less well-engineered sites, the pressure within the borehole may be influenced by the gas extraction taking place in the adjacent cell. In this case, the borehole may be at an underpressure. On newer or better-engineered sites, the boreholes are unlikely to be influenced by the extraction of the landfill gas from the waste and hence at a slight overpressure.

Where individual perimeter boreholes are known to have a history of consistent or frequent elevated levels of landfill gas above the LEL, a zone 1 should be applied internally. Otherwise, a zone 2 applies.

A 3 mm orifice is typical for manual sampling. There are also systems with continuous automatic sampling.

The overpressure is much less than the peak of 80 mbarg assumed for gas wells. The external zone caused by opening the sample point are dependant on the overpressure and can be taken as 0.3 m up to 6 mbarg. Perimeter boreholes may also be opened for water sampling or extraction – a different-sized zone applies for this and should be calculated on a site-specific basis.

5.10 Leachate extraction points

5.10.1 Description

Leachate extraction points are primarily designed to remove liquid (leachate) from the base of the engineered 'cell' (a subsection of the whole landfill void). However, landfill gas is also harvested. They are generally installed along the slope of the wall of the cell or as vertical chambers within the waste mass; they key into the leachate drainage blanket.

There are various orientations: horizontal, side slope risers and vertical. The various types are identical to each other in terms of the area classification, and also similar to gas wells. What follows is a typical example, the principles of which can be applied to other types of leachate extraction systems.

The pipe is commonly a wide-diameter jointed pipe with no flanged joints between the top and the leachate collection chamber, which is a horizontal section of pipe, extending a number of metres, with perforations in the pipe. Inside this is a leachate pumping main.

A pump²⁰ is located in the leachate chamber, in addition to a trigger device²¹. The trigger device is used to monitor the levels of leachate at that point. An alternative to this method is to have a separate pipe placed next to the side riser pipe in which the trigger device may be located. At a pre-set level, the pump automatically switches on and pumps the leachate up the internal pipe. Once it reaches a pre-determined lower level, the pump will automatically switch off.

The control system for the pump is located above ground, usually in the vicinity of the leachate extraction point.

Internal pressures are variable but in normal operation the system would be under vacuum, typically 40 mbarg. When no gas extraction is taking place, positive pressures up to 80 mbarg could be present.

5.10.2 Zoning

Refer to Figure 4. This assembly resembles a gas well and the same area classification generally applies, with a zone 1 above the liquid level and a zone 2 below. There is an external zone 2 of 2.2 m around the seal – see section 5.6. As for the gas well, removal of the dipping cap when the leachate riser is at an overpressure gives an unacceptably large potentially explosive atmosphere with a radius of tens of metres, so the cap should only be removed under a maintenance procedure. Refer to section 5.5 for the possible options.

Below the water level is zone 2 by default. However, if the control system²² to prevent the pump from becoming unsubmerged is considered to be of a high reliability type, then the region below the liquid level may be classified as non-hazardous. Alternatively, if a top-fill pump is used and suitable measures²³ are taken to ensure it does not fall over when lowered into the well and pump itself dry (thereby becoming a potential ignition source), the region below the liquid level may also be classified as non-hazardous.

Leachate is water-based but it is possible it could contain flammable liquids if such liquids have seeped down through the waste. However, compared to the volume of landfill gas evolved, any potentially explosive atmosphere from leachate vapour is likely to be within the zones defined for landfill gas²⁴.

²⁰ Electric, air-driven or other pumps may be used.

²¹ The trigger device could be a transducer, float switch, etc.

²² An appropriately-certified transducers or another means (e.g. undercurrent protection.) of detecting the 'pumping dry' situation are also appropriate if assessed as sufficiently reliable.

²³ Such measures might be, for example, securing the pump on a 'sledge' prior to being offered into the opening of the leachate extraction point; the pump is secured in such a way that it cannot turn over when presented and located in the side riser. For vertical wells, the pump could be supported at the top until it reaches the bottom of the well and therefore cannot turn over.

²⁴ The presence of low flashpoint liquids in the leachate at high ambient temperatures could lead to a vapour/air mixture that exceeds the zone defined for landfill gas. Refer to the relevant ICoP for leachate extraction and treatment.

Figure 4: zoning for a leachate riser

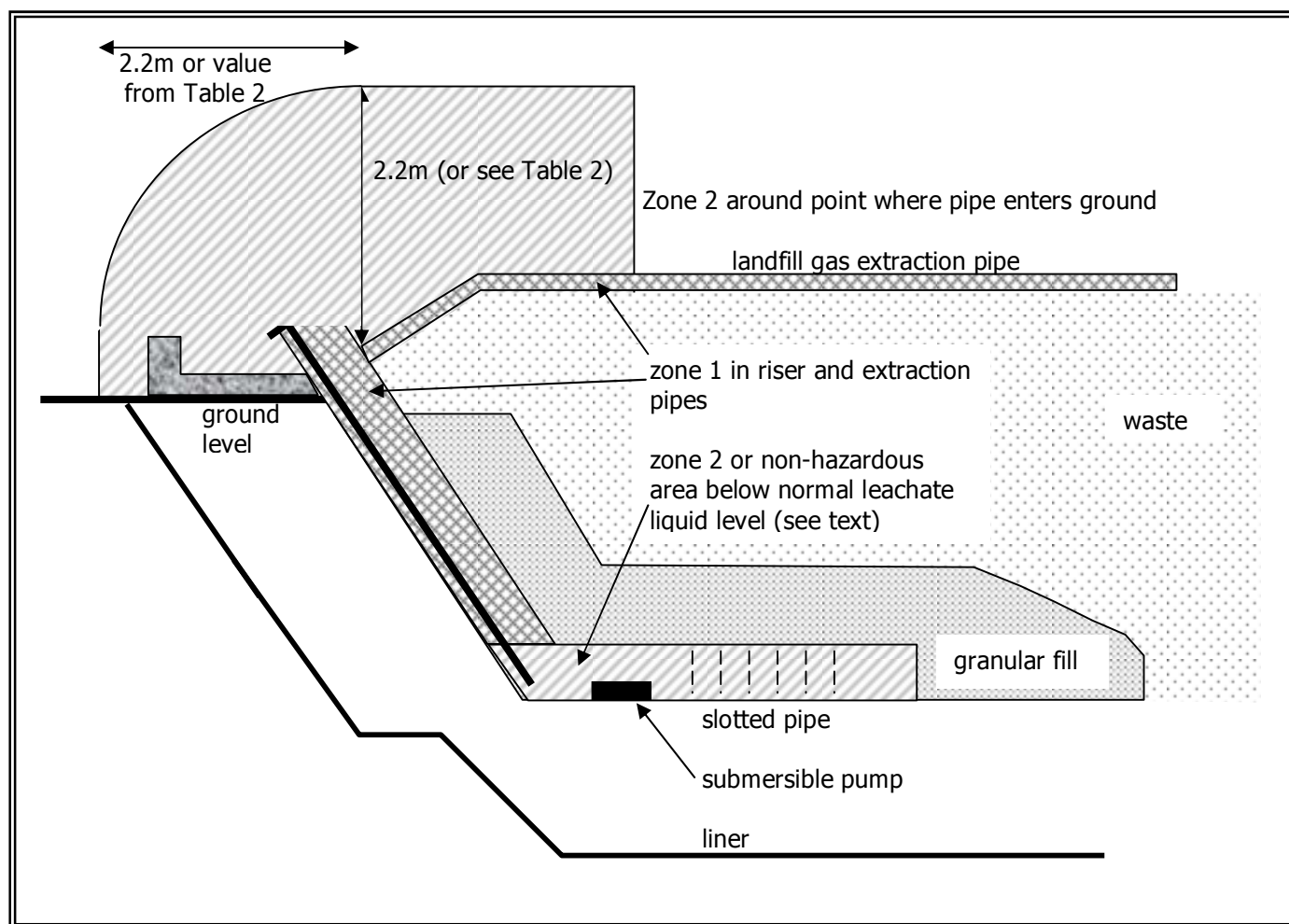

5.11 Leachate recirculation injection

This facility involves penetrating the capping so, as in the case of gas wells and leachate extraction wells, there is the possibility of leaks around the seal. A zone 2 typically of radius 2.2 m applies – see section 5.6.

5.12 Gas collection manifold

5.12.1 Description

The gas collection manifold is of HDPE (or similar) or steel fabrication and is the point where the collection pipes from individual or groups of gas wells are joined together prior to connection to the main gas collector pipeline. Gas quality can be regulated and flow rate adjusted by a valve on each individual pipeline joining the collection manifold. A further regulating valve is located at the exit pipe to the manifold. Generally, sampling valves are fitted to each individual gas pipe entering and exiting the collection manifold.

There are two basic variations:

- 1 open design, used for above-ground manifolds that do not require protection from unauthorised access
- 2 enclosed design used for above-ground manifolds that require protection and also below ground manifolds

The enclosed manifold is located within a chamber constructed of plastic or steel sheet. The chamber is normally fitted with a solid cover or lid. Whilst this type of cover does not offer a good degree of ventilation, open mesh or ventilated covers tend to allow flooding or silting up of the manifold chamber.

In normal operation, the manifold is under suction, up to 150 mbarg. Fault conditions such as damage to a main collection pipe or loss of the gas extraction system may result in the gas pressure within the collection

manifold rising to above atmospheric (maximum 80 mbarg). However, an overpressure within the manifold pipework is a much rarer event than in an individual gas well.

5.12.2 Zoning

Refer to Figure 5. For reasons already explained, the pipework in the gas wells is designated as a zone 1 internally due to the possible ingress of air. However, at each point where the output from two or more wells is combined, the probability of the mixture being within the explosive range falls. At some point in the collection pipework, a less onerous zone is appropriate. It is convenient to designate the manifold as the point at which this change of zone takes place, so the interior of pipework from the manifold valve downstream all the way to the booster should be designated as a zone 2. However, the zone 1 extends from this manifold to the carrier main if the manifold only has one active pipe or because flammable concentrations are detected relatively frequently, e.g. in old sites with lean gas.

Externally, the potential releases are secondary grade:

- ◆ flanges
- ◆ gas sampling valve stems
- ◆ condensate drainage plugs
- ◆ sample points
- ◆ flow monitoring points

As stated above, an overpressure within the manifold pipework is a much rarer event than in an individual gas well, and, for a release to occur, a failure of the containment is also required. Therefore, no zone is applicable around flanges and valves. Removal of the drainage plug, opening of the sample point and flow monitoring point should not be done if the system is at an overpressure, so, again, no external zone is required. In spite of this, the enclosure, if it exists, will be designated a zone 2, since the ventilation is poor and any release would dissipate very slowly²⁵.

Figure 5: zoning for a pipework manifold

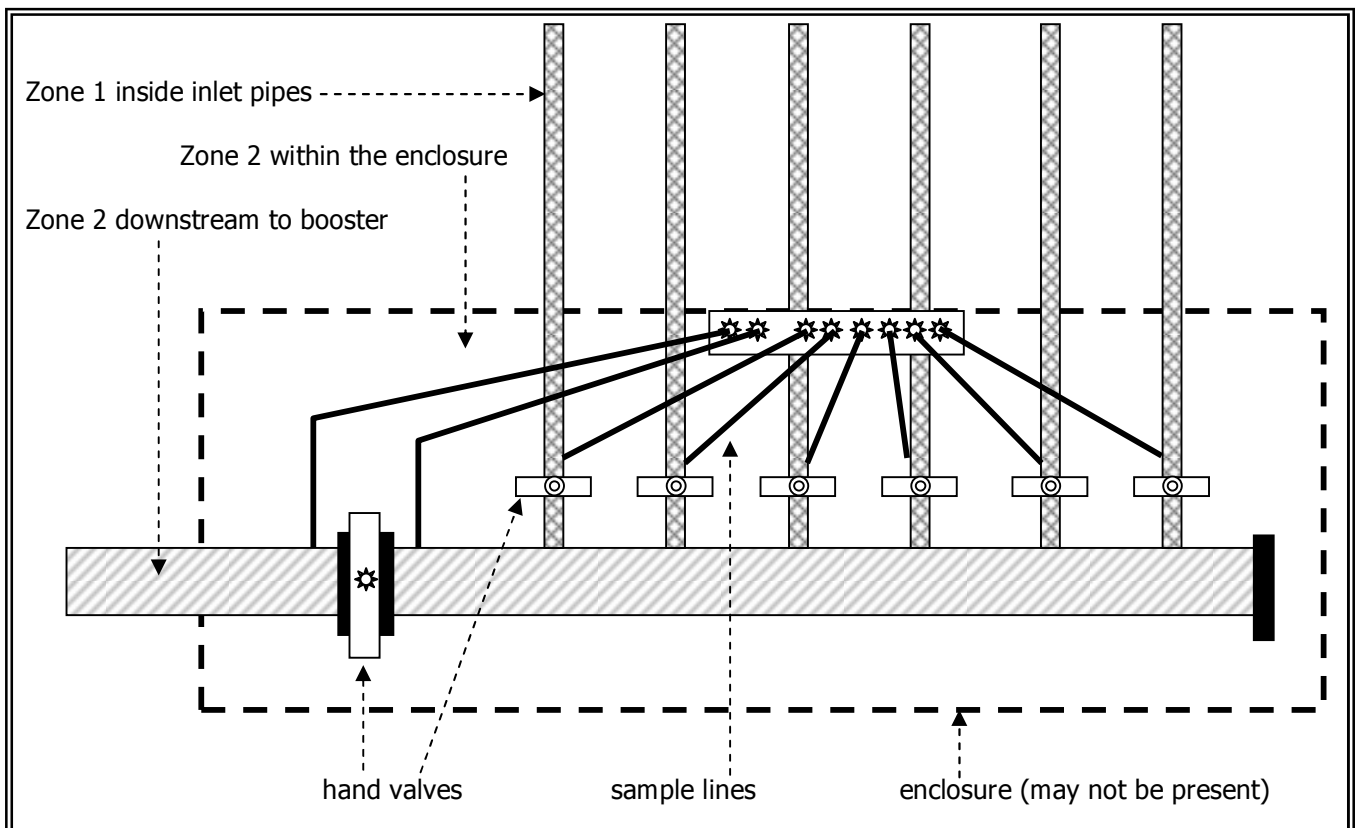

²⁵

Due to the possibility of a dangerous level of landfill gas in the enclosure, there should be limited personnel access, which should only be under a permit-to-work.

5.13 Pipework from manifold to booster

The pipework internally from the manifold (typically) to the booster is classified as zone 2. There are, however, situations on a small number of plants (typically just after a shut-down) in which it is not possible to state with certainty that an explosive mixture within the pipe does not exceed 10 hours a year. Therefore, in a limited number of cases, it will be necessary for the operator to confirm (for example by means of methane monitoring) that instances of feed gas within the explosive range are sufficiently rare to justify a zone 2 designation internally.

It should be noted that, once the booster is switched on, the time during which it is exposed to a 'slug' of explosive gas/air is relatively short, even though this mixture could have been resident in the pipe for a much longer time. Therefore, it is unlikely that the booster will need to be rated for better than a zone 2 application.

5.14 Knock-out pots

Description

The pot is constructed from polyethylene (or similar) and acts as an in-line condensate collection vessel, which is located typically at low points within the main gas service carrier. During normal operation, the pot will be under suction ranging from 40 – 150 mbarg. An overpressure up to 80 mbarg is possible under abnormal conditions.

There are three basic variations, which are identical from an area classification perspective:

- 1 pumped KO pot
- 2 vacuumless KO pot
- 3 barometric drain KO pot

The condensate is not considered to be a source of release due to the low solubility of methane in water. It is collected in the pot and is pumped out. Typically, the pump is automatically-activated when the condensate level reaches a certain level and switches off when the liquid is at the required low level. The pump remains submerged except under abnormal conditions. There may be control systems in the KO pot.

Dependant upon the design, there may be a balance pipe between the main body and the inner sleeve to maintain equal pressures in both areas.

The top of the knock out pot is housed within an enclosure with an opening lid.

Zoning

Refer to Figure 6. For reasons explained in section 5.13, the pipework at this part of the system is a zone 2. Therefore the main chamber of the knock-out pot is also zone 2. The zoning of a typical knock-out pot is shown below.

The inner sleeve (if it exists) usually contains air. However, if the condensate is pumped out to below the level of the perforations, then landfill gas can enter the inner sleeve and, if the level of condensate rises again, it will be trapped along with the air. This mixture could be within the explosive range and cannot readily dissipate, so will persist. Thus, a zone 1 rather than a zone 2 applies for the inner sleeve above the liquid level, zone 2 below. However, if a top-fill (as opposed to a bottom-fill) pump is installed below the liquid level and there is further protection against the pump becoming unsubmerged by means of a level transducer, then the area below the liquid level is a non-hazardous area. Refer to section 5.10.2 for further information.

Leaks into the outer enclosure over the knock-out pot (via imperfectly-sealed cable entries or other routes) are unlikely because the gas underneath is normally at an underpressure (main section) or ambient pressure (inner sleeve). Two faults are required (gas pipe at an overpressure and failure of the seal) for this enclosure to have an explosive atmosphere in it but the ventilation is poor and, as a precaution, a zone 2 will be designated, with a further zone 2 of negligible extent around the hatch.

Note that some knock-out pots are sunk into waste, in which case there is a zone around the Bentonite seal – see section 5.6.2.

Figure 6: zoning for a typical pumped knock-out pot

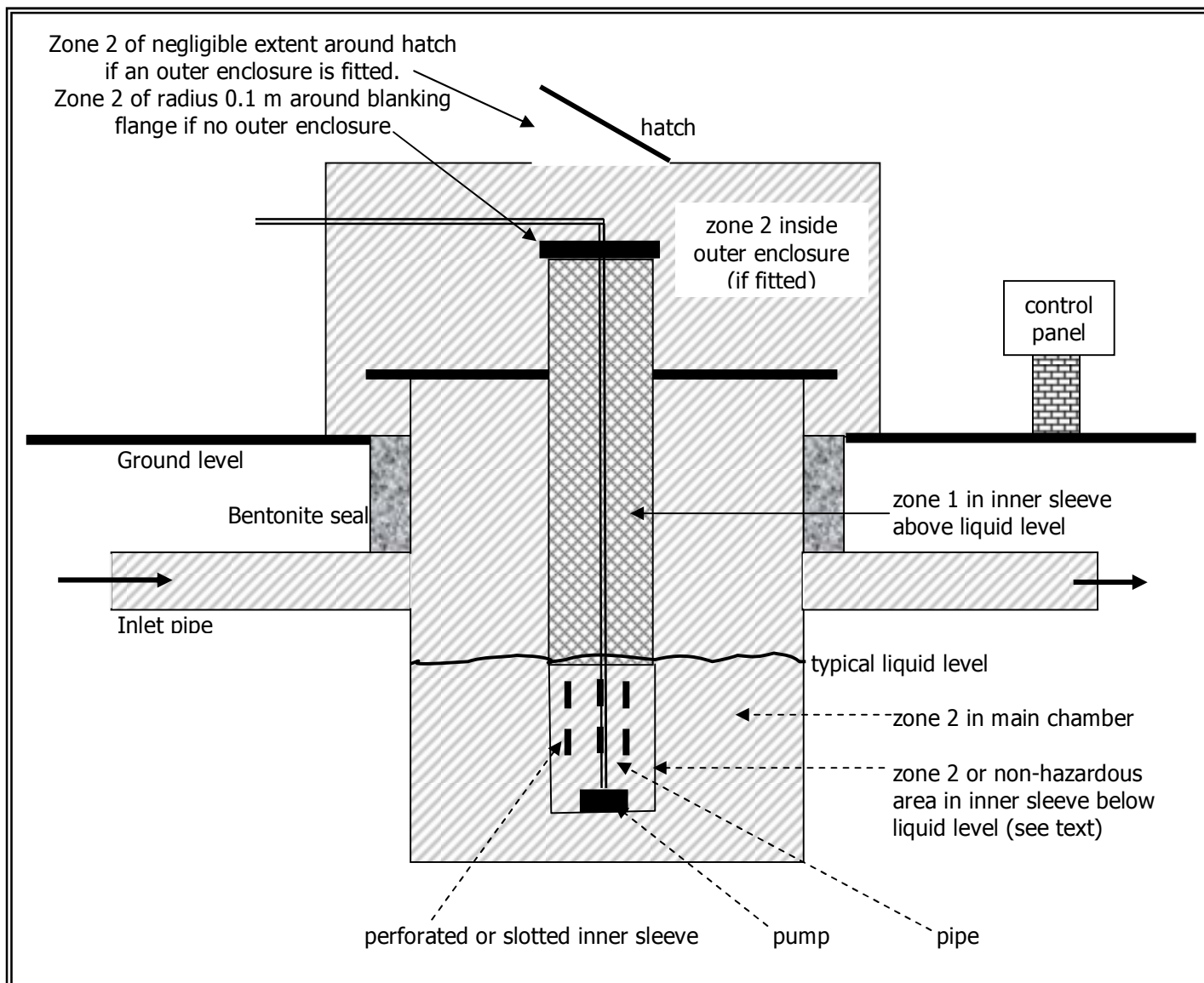

5.15 Passive vents

Modern installations do not include vents but some existing sites have these, typically using 150 mm (6") pipe. The vent is a static or aspiromatic (rotating) cowl and normally has a flame arrestor fitted. The discharge height is typically between 1 m and 3 m. Vents are only installed in relatively unproductive areas where the gas quality is low, so flow rates are low and pressure is limited. The flow rate is unlikely to exceed 5 m³/h. Based on this value and the equations in section 4.5, a zone of extent 1.3 m radius is applicable for dilution to 0.25 LEL. This will be a zone 0, since gas emission is a continuous grade release.

5.16 Drilling operations

Since drilling operations are usually undertaken by outside contractors, this activity is currently outside the scope of this ICoP but is being dealt with in conjunction with the relevant bodies. An ICoP covering this

6 AREA CLASSIFICATION FOR LANDFILL GAS UTILISATION AND COMBUSTION

6.1 Overview of power generation from landfill gas

The following section of this Landfill ICoP deals with all aspects of the landfill gas from the booster onwards. Landfill gas is extracted at a small underpressure (up to 150 mbarg) supplied by the booster, which then generates an overpressure (up to 350 mbarg) for reciprocating engines. Reference section 6.10 for higher pressure systems. This may be regulated to a lower pressure (typically 150 mbarg) for the Landfill Gas Generation Sets (LFGs) used to generate electricity. Power generation from landfill gas typically takes place in a fenced 'Gas Management Compound'. A typical process flow is as follows.

Figure 7: typical process flow in a gas generating compound

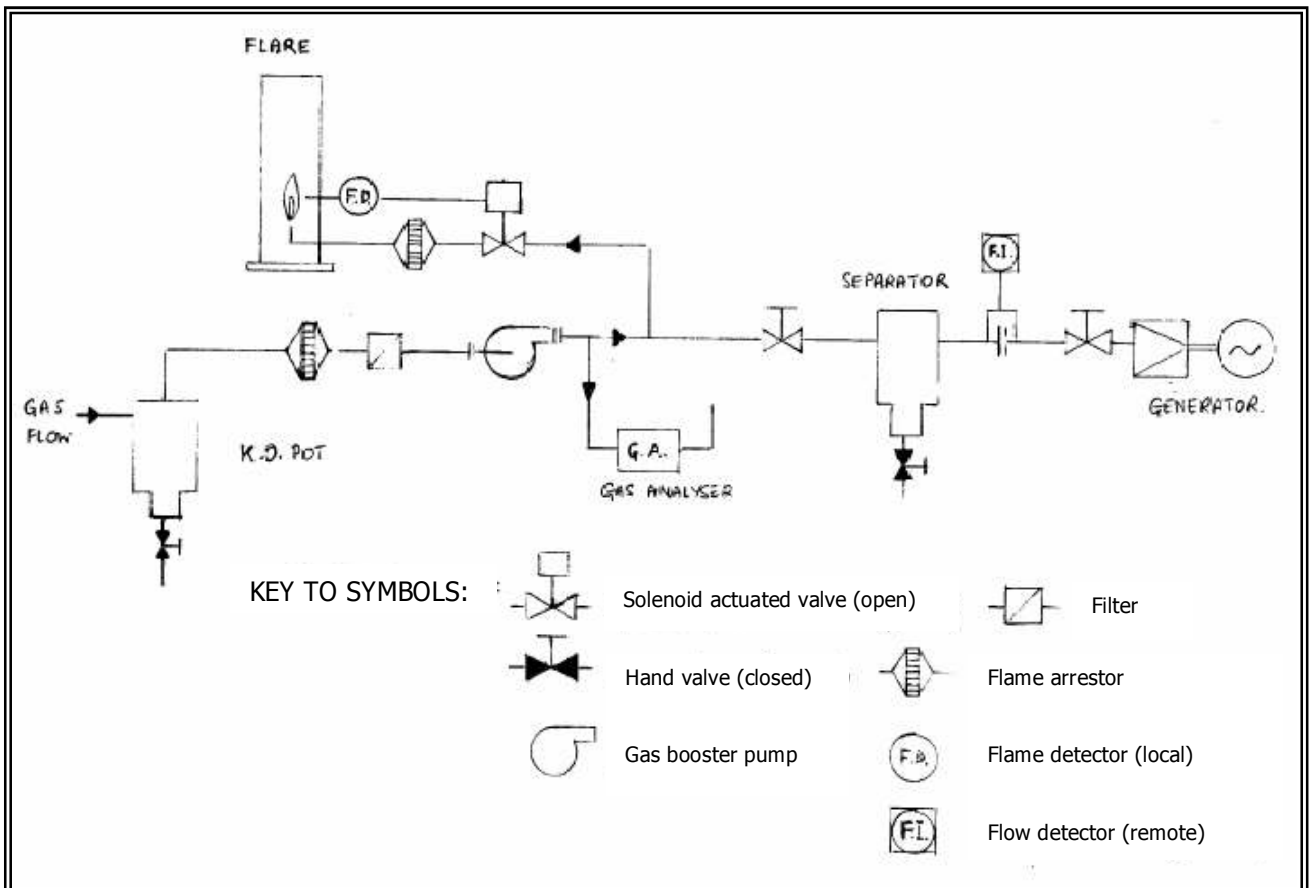

If the feedstock becomes contaminated with oxygen up to a pre-determined level (or the level of methane falls too low for whatever reason), the mix to the engine becomes too lean and generation stops²⁶, usually diverting the feedstock to a flare. Due to the large number of feeder wells to a particular booster, it is highly improbable that the feedstock will actually contain enough oxygen to be within the flammable range, but, for the reasons given in section 5.13, the interior of the pipe to the booster is classified as a zone 2. For this reason, flame arrestors are fitted.

This is a relatively new industry and the majority of plants have been installed since the mid-nineties. Consequently, the equipment is modern and generally follows the latest thinking with regard to ventilation and the installation of explosion-protected equipment where necessary. Older plant may need to be upgraded.

²⁶

The gas below certain calorific value cannot be utilised in the engine, so either low methane or high oxygen (air) content could trigger sending landfill gas to the flare or vent it if it is not possible to flare it safely (<25% CH₄)

Consideration should be given to gas generating compounds built on former landfill sites since the possibility of landfill gas migrating into areas classified as non-hazardous (e.g. switch rooms) has been known to cause an ignition in at least one case.

6.2 Manual sampling

Manual sampling is normally performed by opening the sample point (a 3 mm diameter hole) and connecting a flexible tube that allows a small volume of gas to be drawn through a hand-held gas analyser. The flammable gas is then vented to atmosphere.

Sampling is a normal operation and is classified as a primary grade release, leading to a zone 1. The sample point may be left open, in which case landfill gas at up to 350 mbarg overpressure can escape through a hole of diameter 3 mm. IP15 Table C9(a) gives a 1 m zone for a 4 barg release of gas from a 5 mm hole – the release of landfill gas will be less than this so this value is conservative.

6.3 Continuous gas monitoring

Continuous Gas Monitoring Analysers, where installed, typically have a permanent connection of a 3 mm pipe to the gas main. The analyser is usually located in a small GRP enclosure in the open air. A pump on the analyser pulls through the gas to be sampled, which is then vented to atmosphere via a high-level vent, typically via a flame trap. The inside of the analyser compartment should be classified as a zone 2, with a zone 0 of radius 1.2 m around the vent. To take account of different types of analyser, this zone radius is based on the worst-case assumption of a 350 mbarg pressure via a 3 mm diameter outlet and dilution to 0.25 LEL).

Note: the gas analyser should not be located in an non-hazardous area, such as the control compartment of the engine enclosure. If it is, leakage from the pipework needs to be assessed and a zone extent estimated based on the available ventilation.

6.4 Gas booster – freely-ventilated

The inlet pipe is at an underpressure, so leaks of landfill gas are not considered, thus there is no external zone. Internally, the composition of the gas is such that it is above its upper explosive limit. Very occasionally, it is possible that air can be drawn into the pipe from the waste site, so, to take account of this possibility, the pipework is classified as zone 2 internally. Flame arrestors²⁷ are typically fitted immediately downstream of the booster.

The only potential releases from the booster itself are flanges (see section 5.3) and shaft seals, both potential secondary grade releases. Shaft seal leaks are especially difficult to quantify, since there are many designs and levels of integrity, ranging from basic to highly sophisticated sealing arrangements. The failure of a 'basic' seal can lead to a significant release of gas whereas, at the other end of the spectrum, a high-integrity seal need not be considered as a source of release. It is therefore recommended that the manufacturer is consulted where necessary to obtain a leak aperture and the zone extent calculated from first principles using the equations in section 4.5. In some cases, a decision can be made that the seal is of sufficient integrity such that failure can be considered 'catastrophic' within the definition in EN 60079-10, i.e. a significant leak²⁸ (i.e. one leading to a zone of larger than 0.3 m) is highly improbable.

IGE/SR/25 does not deal with seals of this type, but IP15 Table C6 quotes leak diameters the commonest ("Level I"), less common ("Level II") and rare ("Level III") failure modes of different types of pump seal. The 'levels' take account of the fact that there is no single failure mode for seals. IP15 should be consulted for fuller details on how these levels relate to the 'risk-based approach'.

The values in IP15 may be used *where leak diameter information from the manufacturer is not available*. The zone extents calculated for larger shaft diameters are unrealistic. Taking as an example a booster with a single seal with a throttle bush (or an equivalent level of integrity), IP15 gives a leak diameter of 0.1SD for a 'Level I' failure (SD = shaft diameter).

²⁷ Since these devices are required to halt an incipient explosion, they are classed as 'safety devices' under the ATEX 94/9/EC (Product) Directive; future installations should make use of flame arrestors that are ATEX-marked but retro-fitting of ATEX-marked arrestors is not required for existing facilities (installed before 1 July 2003) provided the existing flame arrestor is fit for purpose, correctly installed and appropriately maintained.

²⁸ EN 60079-10:2003 calculation 4 states that a $V_2 < 0.1 \text{ m}^3$ (i.e. a sphere of radius 0.3 m) allows the ventilation to be assessed as degree 'high'. From the definition of degree 'high' in clause B.3.1, a zone of negligible extent results.

Figure 8: shaft leak diameter

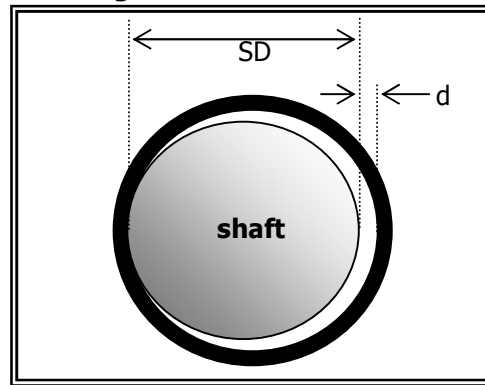

The mass flow rate (g) from a failed seal requires the value of the cross-sectional area of the leak (A), where

$$A = \pi ([SD+d]/2)^2 - \pi (SD/2)^2$$

IP15 does not give zone extents at such low pressures, so the zone extents for dilution to 0.5 LEL are calculated from the equations used in section 4.5 of this ICoP. It can be seen from the leak area in Table 3 below that these are unrealistically high, particularly for larger shaft diameters, leading to zone radii that are also unrealistically high.

Table 3: Booster pump at 150mbarg – level I leak (shaft diameters 10 to 100 mm)							
Shaft diameter (mm)	10	15	25	40	50	80	100
Leak area (mm ²)	16.5	37.1	103	264	412	1056	1649
Zone 2 radius (m)	1.1	1.6	2.8	4.7	6.0	10	13

Table 4: Booster pump at 200mbarg – level I leak (shaft diameters 10 to 100 mm)							
Shaft diameter (mm)	10	15	25	40	50	80	100
Zone 2 radius (m)	1.1	1.8	3.0	5.1	6.5	11	14

Table 5: Booster pump at 250mbarg – level I leak (shaft diameters 10 to 100 mm)							
Shaft diameter (mm)	10	15	25	40	50	80	100
Zone 2 radius (m)	1.2	1.9	3.2	5.4	6.9	11	15

Table 6: Booster pump at 300mbarg – level I leak (shaft diameters 10 to 100 mm)							
Shaft diameter (mm)	10	15	25	40	50	80	100
Zone 2 radius (m)	1.3	2.0	3.4	5.7	7.2	12	15

Table 7: Booster pump at 350mbarg – level I leak (shaft diameters 10 to 100 mm)							
Shaft diameter (mm)	10	15	25	40	50	80	100
Zone 2 radius (m)	1.3	2.0	3.5	5.9	7.5	13	16

6.5 Gas booster – enclosed

Where the gas booster is inside an enclosure (typically an acoustic enclosure), there is the additional hazard of an explosion if a gas/air mixture is ignited. This event shall be made sufficiently improbable by supplying a suitable level of ventilation to the enclosure. Releases are secondary grade and therefore, by definition,

improbable; ventilation failure is also improbable. Area classification does not normally consider two improbable events happening at the same time, so it is not necessary to consider a leak when the ventilation has failed provided the ventilation is reliable.

To ensure that secondary grade releases do not persist in excess of the time allowed for a zone 2 to be appropriate, IP15 section 6.3.1 requires 12 air changes/hour. This may be produced by forced ventilation or by adequate openings in the structure to allow a sufficient air change rate by natural ventilation. Rather than calculate the extent of the zone within the enclosure, it is simplest to designate a zone 2 throughout the enclosure, with no external extent (since forced or outdoor natural ventilation will rapidly dilute landfill gas from a small leak). A more rigorous approach is to use the equations in EN 60079-10:2003 section B.4.2, which may be used to calculate the hypothetical volume (V_z); if this is negligible²⁹ (less than 0.1 m³), then no zone is required.

6.6 Flame arrestor

Flame arrestors can be considered as flanges for area classification purposes – see section 5.3.

6.7 Separator/knock-out vessel

Description

This is typically the last vessel prior to entry into the engine compartment. It is designed to remove the last traces of condensate from the feedstock and should be located outdoors. There are various designs. Condensate is removed either by a manual drain or by a float-operated valve.

The manual drain allows liquid to be removed, but this is usually followed by a small release of landfill gas, which tells the operator that the liquid has all been drained. The tap is closed at this point.

The float-operated valve opens to allow condensate out when the liquid level rises to a certain point. It closes again when the liquid level falls.

²⁹

EN 60079-10:2003 calculation 4, conclusion states that a $V_z < 0.1 \text{ m}^3$ (i.e. a sphere of radius 0.3 m) allows the ventilation to be assessed as degree 'high'. From the definition of degree 'high' in clause B.3.1, a zone of negligible extent results.

Zoning: manual drain type

Refer to Figure 9. For reasons explained in section 6.4, the pipework at this part of the system is a zone 2. Therefore the main chamber of the separator is also zone 2. A zone 1 radius 1 m is assigned³⁰ around the drain point to take account of the primary grade release of a small volume of landfill gas. Note that this zone should not impinge on the engine enclosure.

Figure 9: zoning for separator/knock-out vessel with manual drain

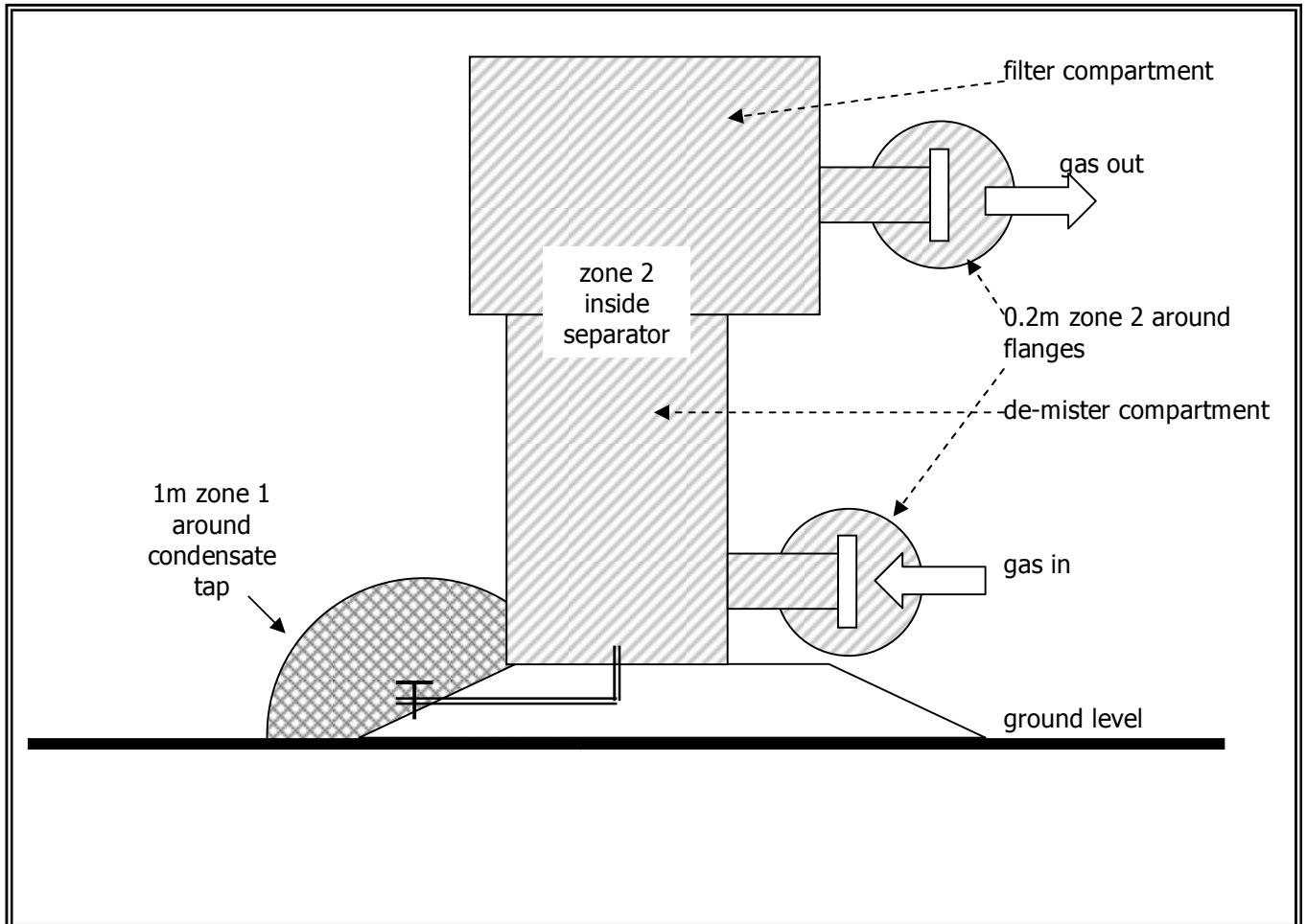

³⁰

IP15 Table C9(a) gives a 1 m zone for a 4 barg release of gas from a 5 mm hole – the release of landfill gas will be less than this so this value is conservative.

Zoning: float-operated valve type

Refer to Figure 10. The separator is a zone 2 internally. This is a sealed system and the only releases are secondary grade around flanges, for which a zone radius of 0.2 m applies (see section 5.3).

The usual failure mode is for the valve to jam shut. It is feasible that the valve can jam open, in which case landfill gas will be released when all the liquid has been drained out. This will be treated as a secondary grade release. The seal may fail to bed properly and give a slow release, so will be treated as a primary grade release and assigned a 0.3 m zone 1. However, these releases do not occur around the separator itself, but should be considered where the condensate pipe ends.

Figure 10: zoning for float-operated valve type separator

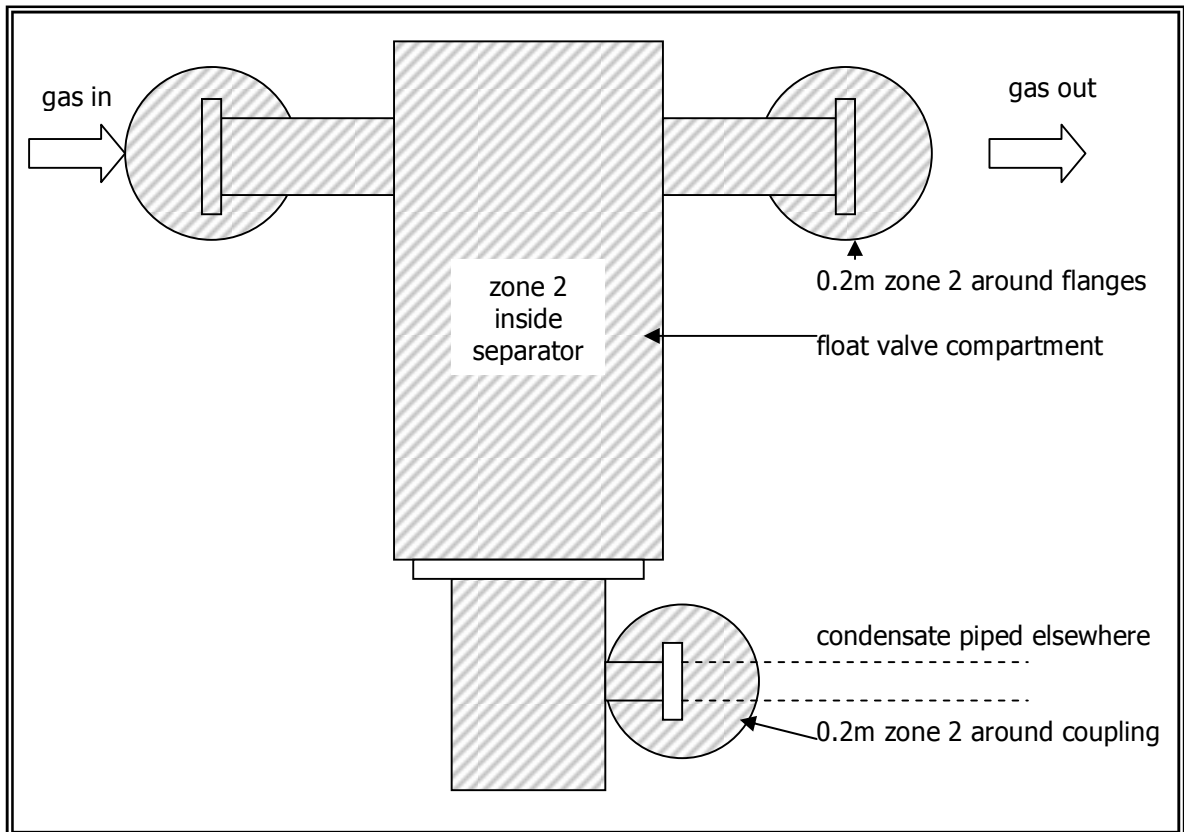

6.8 Condensate cyclone/separator

The area classification is the same as for separators.

6.9 In line gas filter systems

An in-line filter comprises a fabricated or cast housing, with a lid and a drain point, and flanged connections to the pipe. Internally, the pipework is zone 2 for the reasons given in section 6.4. All leaks are secondary grade releases and are dealt with in section 5.3.

The lid is removed at intervals (rarely more than annually), but this activity will be performed under a maintenance procedure, so is outside the scope of area classification.

6.10 Gas receivers (pressurised systems, gas compressors)

These items involve gas pressures up to 4 barg and are outside the scope of this ICoP. However, reference may be made to

- ◆ HSE Guidance Note PM84^T – Gas turbines used for power generation
- ◆ HSE Information document 482/7^U - safety of small gas turbines used for power generation.
- ◆ IGE/UP/6 – Gas compressors
- ◆ IGE/SR/23 – Venting natural gas
- ◆ IGE/SR/25 – Hazardous area classification

For general guidance, the zone radii in freely-ventilated outdoor locations for typical leak apertures calculated using the equations in section 4.5 are given in the table below. A pressure of 4 barg and a temperature of 10°C is assumed.

Table 8: zone radii from releases at 4 barg

	Leak aperture (mm ²)		
	0.1 (leak from high integrity joint)	0.25 (typical flange or valve-stem leak)	2.5 (major flange or valve-stem leak)
zone radius (m) for gas at 4 barg	0.2	0.3	0.9

6.11 Engine enclosures

Engine enclosure fall into three categories:

- 1 Engine Containers
- 2 Compartmentalised Engine Halls
- 3 Open Engine Halls

All new gas engine systems should comply with IGE UP/3. This ICoP deals with all three types provided that:

- Control rooms are separate from the engine compartment and cables passing through dividing walls are appropriately sealed.
- Connecting doors are normally shut (except for access) when the engines are running and landfill gas may be present in the engine compartment.
- They have forced draft or convection ventilation; care should be taken that the inlet for this ventilation should not be located within a zone 2 created by other sources. This ventilation can also be used to supply engine combustion air or this may be sourced independently from a location external to the container.
- Ventilation for the control room is independent of engine hall ventilation and generally is for electrical cooling and personal comfort purposes.
- Engine housings are fitted with appropriately installed and maintained explosive gas detection.

6.11.1 Engine Containers

Typically, this is a metal container with two compartments, one for the control equipment and a larger compartment housing the engine.

6.11.2 Compartmentalised Engine Halls

This is a large engine hall with multiple engine sets. Each set is housed within a separate enclosure with no free air movement between them and other areas. Control units are either located in a common passageway connecting the engine compartments or in a separate control room.

6.11.3 Open Engine Hall

This consists of a large hall containing multiple engine units without any permanent gas tight divisions between engines. Each engine is fed independently with landfill gas, but usually ventilation, air supply and other systems are common. Control rooms and other areas are connected to the engine hall.

6.11.4 Zoning

The larger compartment housing the Landfill Gas Generation Set will have numerous secondary grade releases from joints and seals. There should be no primary or continuous grade releases. Although zoning should be considered, boiler rooms (to which this is similar) have historically not been zoned. As a result, uncertified electrical equipment may be installed. The relevant standard in the UK is BS 5885^V, which states that, "Because of the very low risk of presence of flammable gases in the vicinity of burner pipework and control equipment installed in accordance with this standard and other recognised codes, unless a hazard can exist from some extraneous source then the area may be declared non-hazardous".

6.11.5 Ventilation

To ensure an adequate degree of ventilation, IP15 section 6.3.1 recommends 12 air changes/hour. Every part of the enclosure that contains potential releases should have this level of ventilation, so the total air change rate may exceed 12/h. This is not usually sufficient to reduce the zones to negligible extent. Therefore, where the integrity of the pipework/equipment is in doubt and a risk assessment shows that there is a significant risk to personnel (e.g. where workers are frequently in or around the enclosure), a mitigating measure might be to install gas detection equipment. However, the number and location of detectors is critical, as is the routine calibration and testing. Excessive reliance should not be placed on a system of gas detection without ensuring that it can reliably detect leaks from all the potential leak sources.

6.11.6 Further guidance

The following guidance is outside the scope of area classification but is provided for information.

Most engines take their air from inside the compartment, thus improving the ventilation. However, one of the most likely times for a leak to occur is just after a maintenance operation involving breaking a pipe joint. When the pipework is pressurised again, the engine may not be running and the additional ventilation will not be available. Maintenance procedures should rigorously ensure that there is a suitable level of ventilation during all phases of operation, including maintenance.

Many engine compartments contain the slam-shut valve, so it is possible that a leak from a joint upstream of the valve could release landfill gas into the engine compartment even when the supply is apparently isolated. This should be considered when assessing the ventilation. Ideally, such valves should be located outside the compartment where this is practicable.³¹

6.12 Multi-engine facilities

6.12.1 Open engine halls

The ventilation characteristics of open engine halls are likely to be less well defined compared to bespoke engine enclosures described in the previous section. They should, however, be treated in the same way, i.e. not zoned provided the ventilation is assessed as adequate.

6.12.2 Individual enclosures

As for open engine halls.

6.13 Flares and associated pipework

This section applies to flares without a venting facility. For flares with the facility for venting large volumes of unburnt gas, see section 6.14. There are many designs of flare – the information in this section is for guidance only and a site-specific evaluation will always be required.

Joints and valves associated with a flare will be outdoors and are dealt with in section 5.3. The area classification implications of the flare itself require consideration of possible fault conditions. The pilot is lit by a spark from the igniter. If this does not occur, the system activates the igniter a further number of

³¹

Note: on gas engine generating sets with a gas input of 1200 kW (approx. 400 kW electric output), a valve proving system is necessary (IGE UP/3 – Gas Engines). If this check takes place on shut down, the possibility of the upstream valve not fully closing is also protected. Consideration should also be given to items between the proving system and the up stream manual valve. e.g. filters.

times and then shuts down if the pilot does not light. Some systems use permanently-lit pilots (using landfill gas or propane). The unburnt pilot gas is released inside the flare stack, so no zoning is required for this level of flow, since it is in a region usually containing a flame. Only when the pilot is lit is a large flow of gas possible.

If the flame fails, a slam-shut valve operates. Some systems will then automatically go through further ignition cycles, whereas for others this is manually initiated.

For there to be a significant release of unburnt gas, a number of failures are required, so such a situation will be treated as a 'catastrophic' failure³² of the flare control system and therefore outside the level of probability dealt with in area classification. A risk assessment, however, is required.

There is, consequently, no zone around the top of the flare stack unless the flare control system is so rudimentary that major releases are considered reasonably foreseeable.

6.14 Vents

Various vents occur in landfill gas power generation operations:

- 1 purge points are used to blow the gas down newly-installed pipe.
- 2 relief valve vents associated with pumps that do not vent back into the suction side

Venting of new pipework should be carried out to IGE UP/1^W. Purge points should be sized to suit the IGE UP/1 procedures. Ideally, all purge points should be valved *and* capped or plugged, which avoids the hazardous area consideration in normal plant operation.

Venting of new or re-commissioned pipework is an infrequent, controlled procedure and should be carried out with its own risk assessment (sometimes involving with permit to work procedures). If carried out to the IGE procedure, the activity has a short purge time (a few minutes). The extent of the potentially explosive atmosphere should be monitored and therefore there should be no ignition sources present (e.g. by ensuring that engines, boosters and electrical equipment are all switched off).

For a properly-designed vent, the vented gas will be unimpeded and directed upwards. The main consideration is the possible extent of any 'downward dispersion'³³, since this may affect operations at ground level. IGE/SR/25 quantifies downward dispersion for various pipe diameters and vent heights, but is independent of the maximum release rate, since downward dispersion mainly occurs at low release rates.

Vent pipes with an internal diameter of under 15 mm are not covered in IGE/SR/25.

Table 9: downward dispersion of potentially explosive atmospheres from outdoor venting

Internal diameter of pipe (mm)	Height of vent (m)			
	≥1	≥2	≥3	
	Downward dispersion below vent tip (m)			
	vertically (0.4h + 3d)*		horizontally (IGE/SR/25 table 7)	
15	1.1	1.1	1.3	0.75
25	1.1	1.1	1.3	1
40	1.2	1.2	1.4	2
50	1.2	1.2	1.4	3

* h = height of vent tip above ground in m; d = internal vent tip diameter in m.

³² See section 4.2.4

³³ 'Downward dispersion' is the extent of the zone below the source of release for a vent pointing vertically upwards.

APPENDIX 1 REFERENCES

The following publications were referenced in compiling this document:

- A Dangerous Substances Explosive Atmospheres Regulations:2002 ('DSEAR') regulation 7 requires area classification to be undertaken
- B EN 60079-10:2003 - Electrical apparatus for explosive gas atmospheres - Part 10: Classification of hazardous areas (technically identical to IEC 60079-10:2002)
- C Institution of Gas Engineers: IGE/SR/25: Hazardous Area Classification of Natural Gas Installations, 2000
- D ATEX Directive 1999/92/EC: Minimum requirements for improving the safety and health protection of workers potentially at risk from explosive atmospheres – also known as the 'ATEX 137 Directive' or 'ATEX Worker Protection Directive'
- E A. McMillan: Electrical installations in hazardous areas, Butterworth Heinemann, 1998.
- F BS 6133:1995 – Code of Practice for the safe operation of lead-acid stationary batteries
- G British Compressed Gas Association – numerous codes and guidance notes
- H EN61241-10:2004: Electrical apparatus for use in the presence of flammable dust – Part 10: Classification of areas where combustible dusts are or may be present
- I HSG51: The storage of flammable liquids in containers, 2nd Edition, 1998
- J HS(G)113:Lift trucks in potentially flammable atmospheres, 1996
- K HSG103: Safe handling of combustible dusts: precautions against explosions, HSE Books, 2003
- L Environment Agency Landfill Directive LFTGN03, Guidance on the Management of Landfill Gas, sec. 6.3.3.
- M Environment Agency publication LFTGN03: Guidance on the management of landfill gas, page 53, section 6.2.3, downloaded August 2005.
- N Guidance on the Management of Landfill gas, document LFTGN 03, September 2004, Environment Agency
- O Guidance for monitoring trace components in landfill gas, document LFTGN 04, September 2004, Environment Agency
- P BS EN 1127-1:1998 – Explosive atmospheres – explosion prevention and protection: Part 1: basic concepts and methodology
- Q Area Classification Code for Petroleum Installations, Part 15, Third Edition, 2005, Institute of Petroleum (IP15)
- R Environment Agency Landfill Directive LFTGN03, Guidance on the Management of Landfill Gas, sec. 6.3.3.
- S Sira Area Classification Manual, 2005, chapter 4
- T HSE Guidance Document PM84: Control of safety risks at gas turbines used for power generation. June 2000
- U HSE Information document 482/7 "Control of health and safety risks from small gas turbines used for power generation
- V BS 5885-1:1988: Automatic gas burners. Specification for burners with input rating 60 kW and above (partially replaced by BS EN 676:1997)
- W IGE UP/1 Ed 2: Strength testing, tightness testing and direct purging of industrial and commercial gas installations